

# SPS 30000 STIFF BOOM CRANE

IDEAL LIFTING SOLUTION FOR 3 AXLE TRUCKS



# TECHNICAL SPECIFICATIONS

## Product Description

- SANY PALFINGER produces according to European Quality Standards to ensure reliability, performance and safety in the industry
- High tensile strength extension booms to optimize lifting height and working range
- The wide outrigger span ensures stability in all mounting situations
- High safety factor with greater reliability
- Piston pump option for reliability, efficiency, and extended lifetime
- Standard package includes
  - Emergency stop button
  - Working light
  - High pressure filter
  - Over-winding stop

## Technical Data

Basic Data	SPS 30000B	SPS 30000C
Rated Lifting Moment	30 mt	30 mt
Rated lifting capacity	12000 kg (2.5 m)	12000 kg (2.5m)
Max. outreach	14.5 m	18.1 m
Max. lines of the hook	6	6
Slewing angle	Continuous	Continuous
Boom raising angle	0 ~ 75°	0 ~ 75 °
Max. lifting height (the measurement from the ground after the outriggers fully extended)	16.5 m	20.5m
Length of the boom system (retracted)	5.4 m	5.6m
Length of the boom system (fully extended)	14.8 m	18.5 m
Boom sections	4	5
Outrigger span (fully extended)	6000 (mm)	6000 (mm)
Recommended Flow Rate	60 ~ 90 L/min	60 ~ 90 L/min
Operating pressure	30 Mpa	30 Mpa
Recommended oil tank capacity	200 L	200 L
Crane moment (dynamic)	507.3 kNm 51.7 mt	507.3 kNm 51.7 mt
Torsional moment (dynamic)	30.0 kNm 3.1 mt	30.0 kNm 3.1 mt
Crane Weight	4200 kg (Floor Control) 4200 kg (High Seat)	4650 kg (Floor Control) 4650 kg (High Seat)

# LIFTING CHART

SPS 30000B

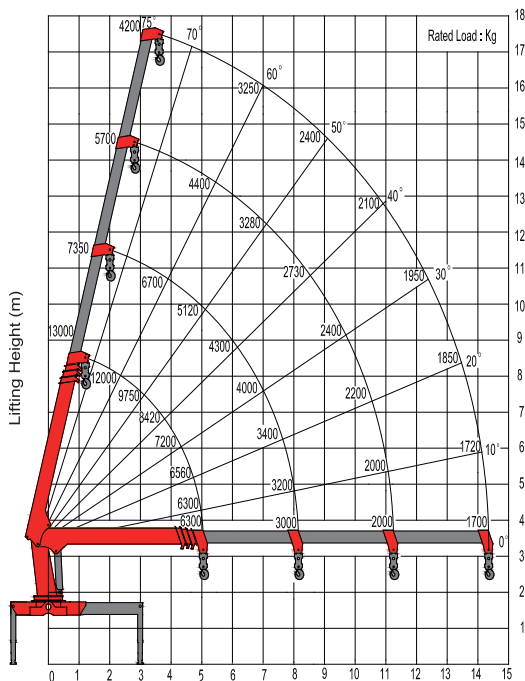

SPS 30000C

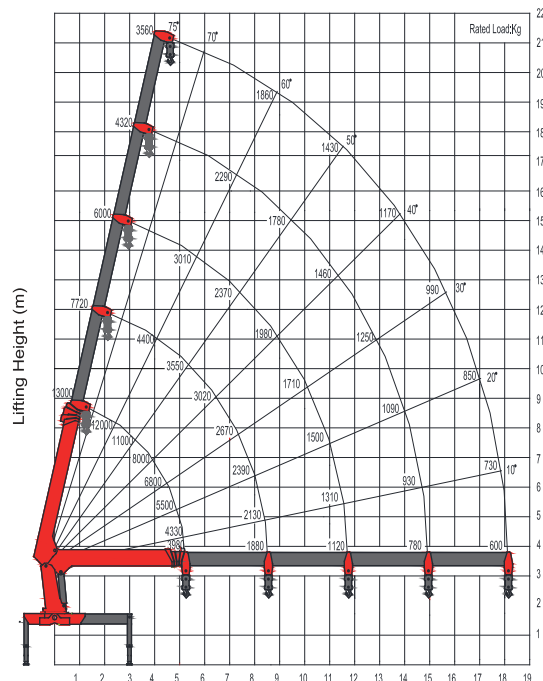

NOTE

The above lifting height and boom angles are based on a straight (unladen) boom. Allowance should be made for boom deflection under laden conditions. Lifting capacities must not exceed 85% of tipping load.

# CRANE DIMENSION

SPS 3000B-F/L

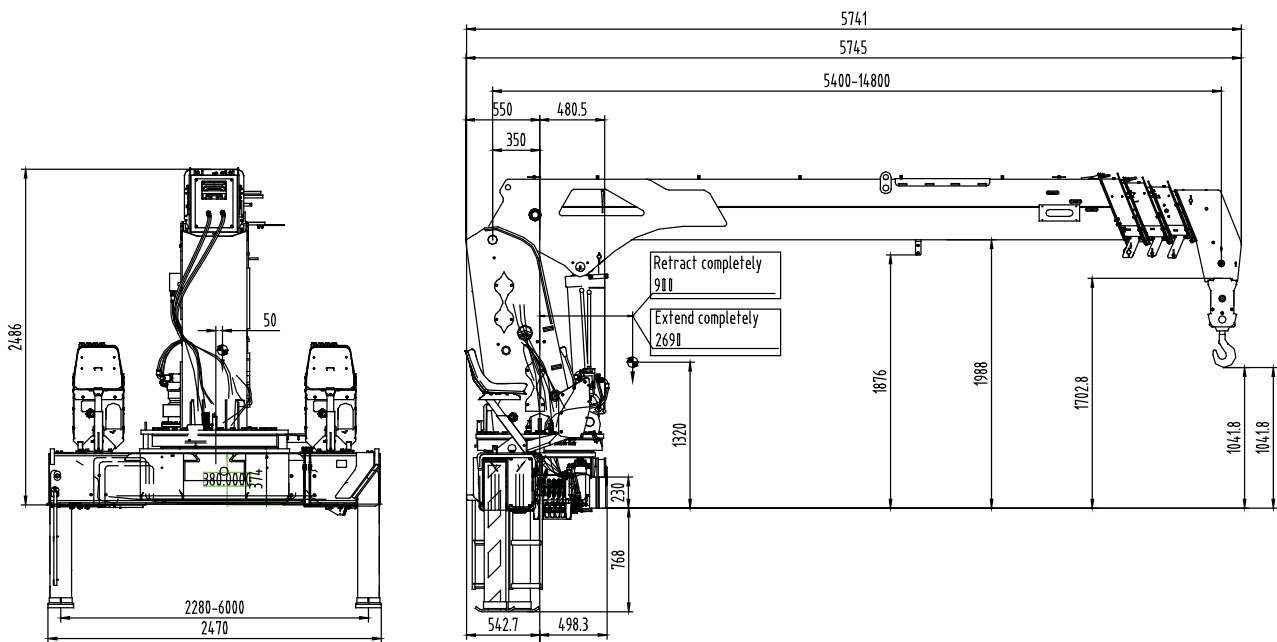

\*The actual product dimensions can vary depending on the operational equipment.

# FEATURES & OPTIONS

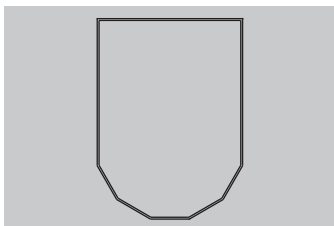

## Octagonal Boom Profile

- High strength and rigidity due to octagonal cross section



## High Tensile Steel

- High Tensile Steel: HG785, SC960
- Able to withstand higher forces



## Overload Protection System

- Built-in safety function
- Protects the crane against overloading



## Working Light

- Safer operations in dusty and dark working conditions
- Optimal visibility for work



## High Pressure Filter

- Ensures proper functionality and longer lifetime of crane



## Proportional Hydraulic System

- Sensitive and stable controls for precise operation
- Operator is able to utilize multiple functions simultaneously



## Load Indicator

- Provides operators with important information on possible overloading and lifting conditions



## Two Speed Winch

- Designed to maximize efficiency
- The winch rope speed can be doubled when the load carried is less than half of the maximum load

PALFINGER ASIA PACIFIC PTE LTD  
3 International Business Park  
Nordic European Center | #05-25/26  
609927 | Singapore  
T: +65 6591 9191  
asia@palfinger.com

Cranes shown in the leaflet are partially optional equipped and do not always correspond to the standard version. Country-specific regulations must be observed. Dimensions may vary. Subject to technical changes, errors and translation mistakes.