

DIN 15018	H1 / B3
BGL 2125	0071
Max. Tragfähigkeit Lifting capacity Force de levage	5.0 t

PEINER SK 76

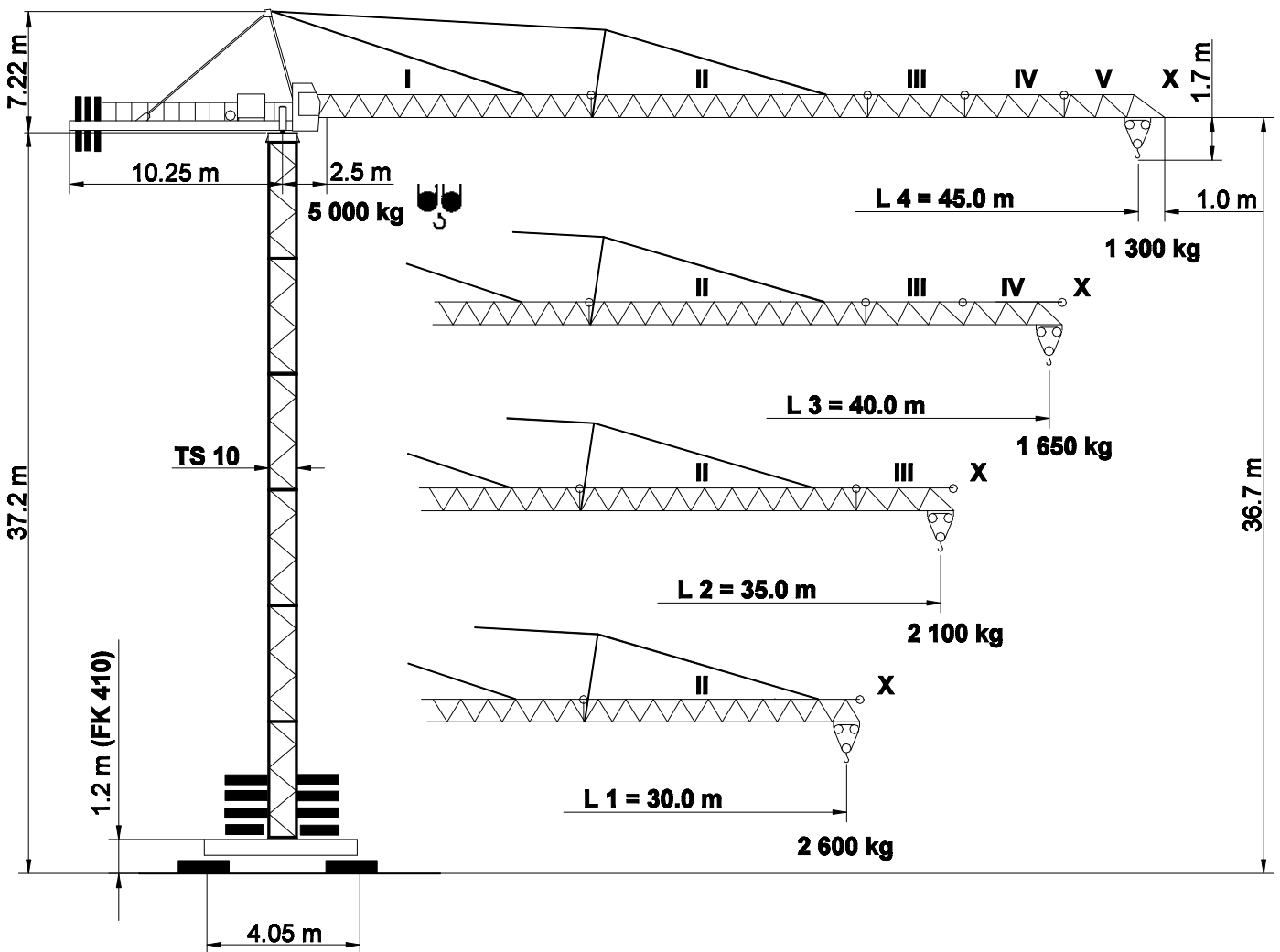
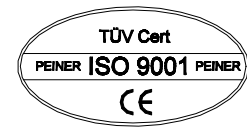

Unsere Vertretung:
Our representative:
Notre représentant:

SK 76

Turmkombinationen, Hakenhöhen, Eckkräfte, Zentralballast

Combinations of tower section, hook heights, forces acting per corner, base ballast

Combinations possibles et hauteurs sous crochet, pressions par coin, contreponds central

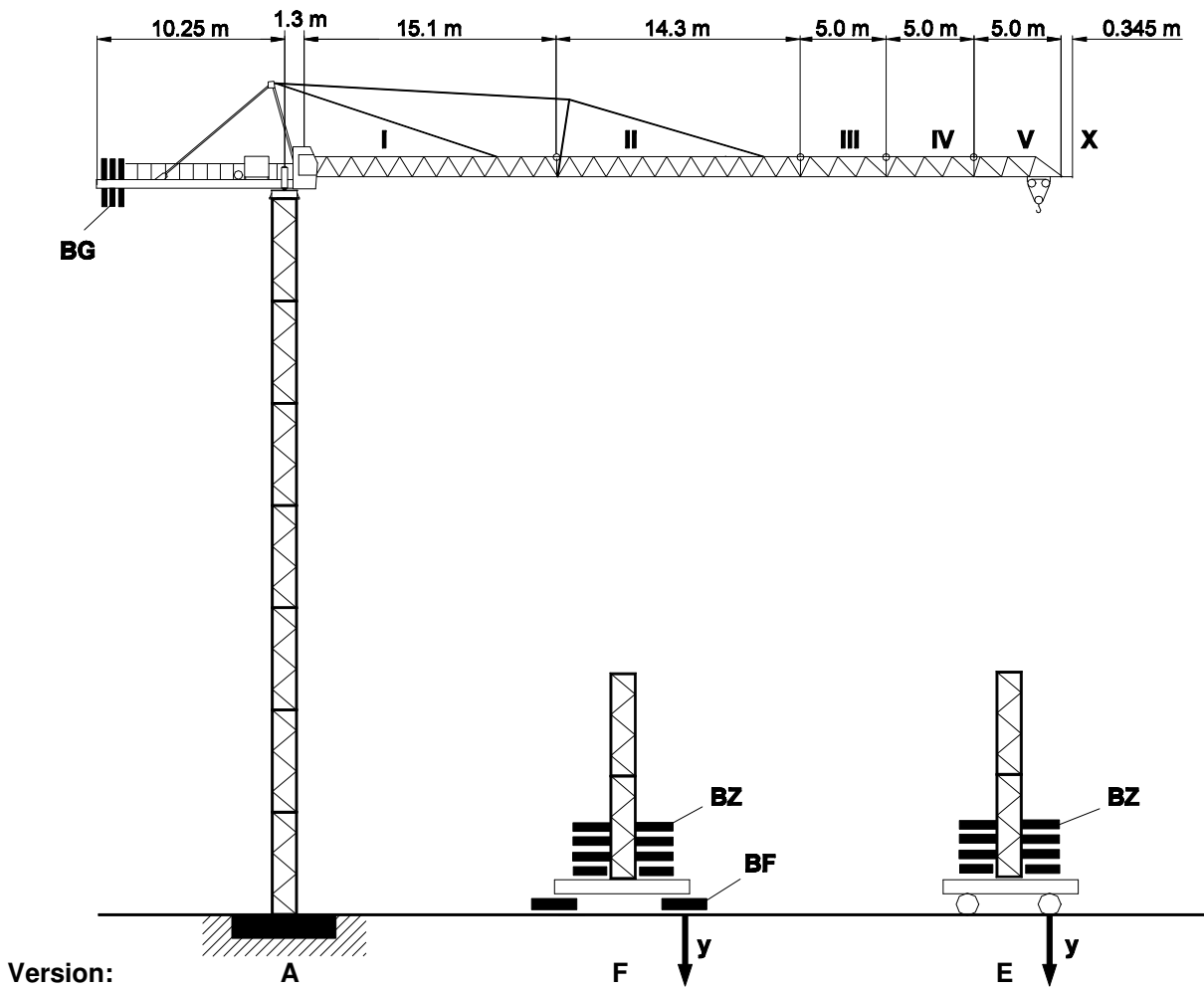

Version:

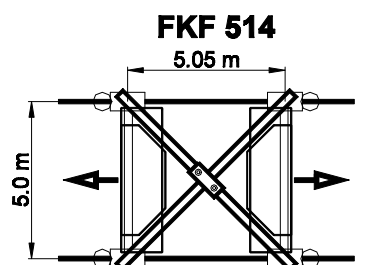
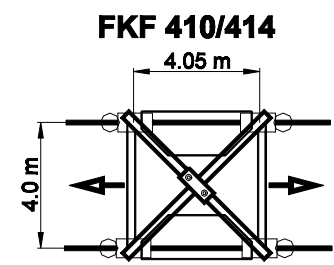
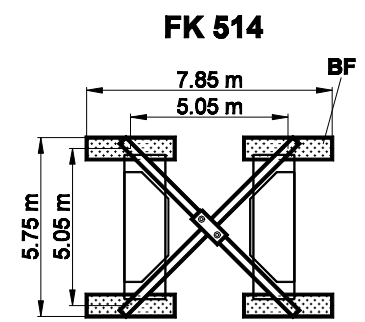
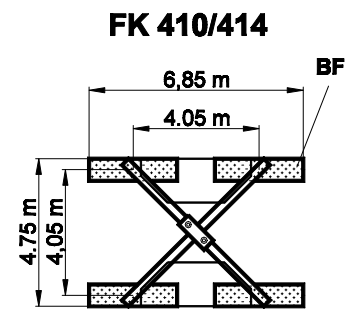
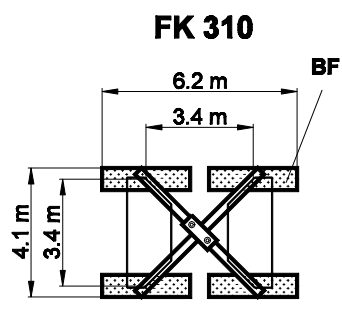

Bodenauflagen

Ground support
Support sol

Version:

A

F

F / SP

E

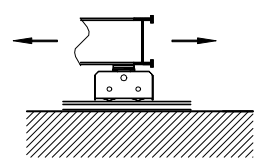
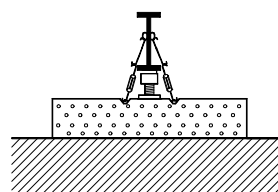
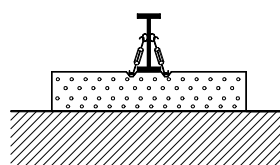
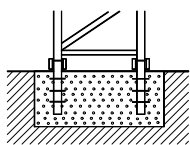

SK 76 Turm / Tower / Tour TS 10

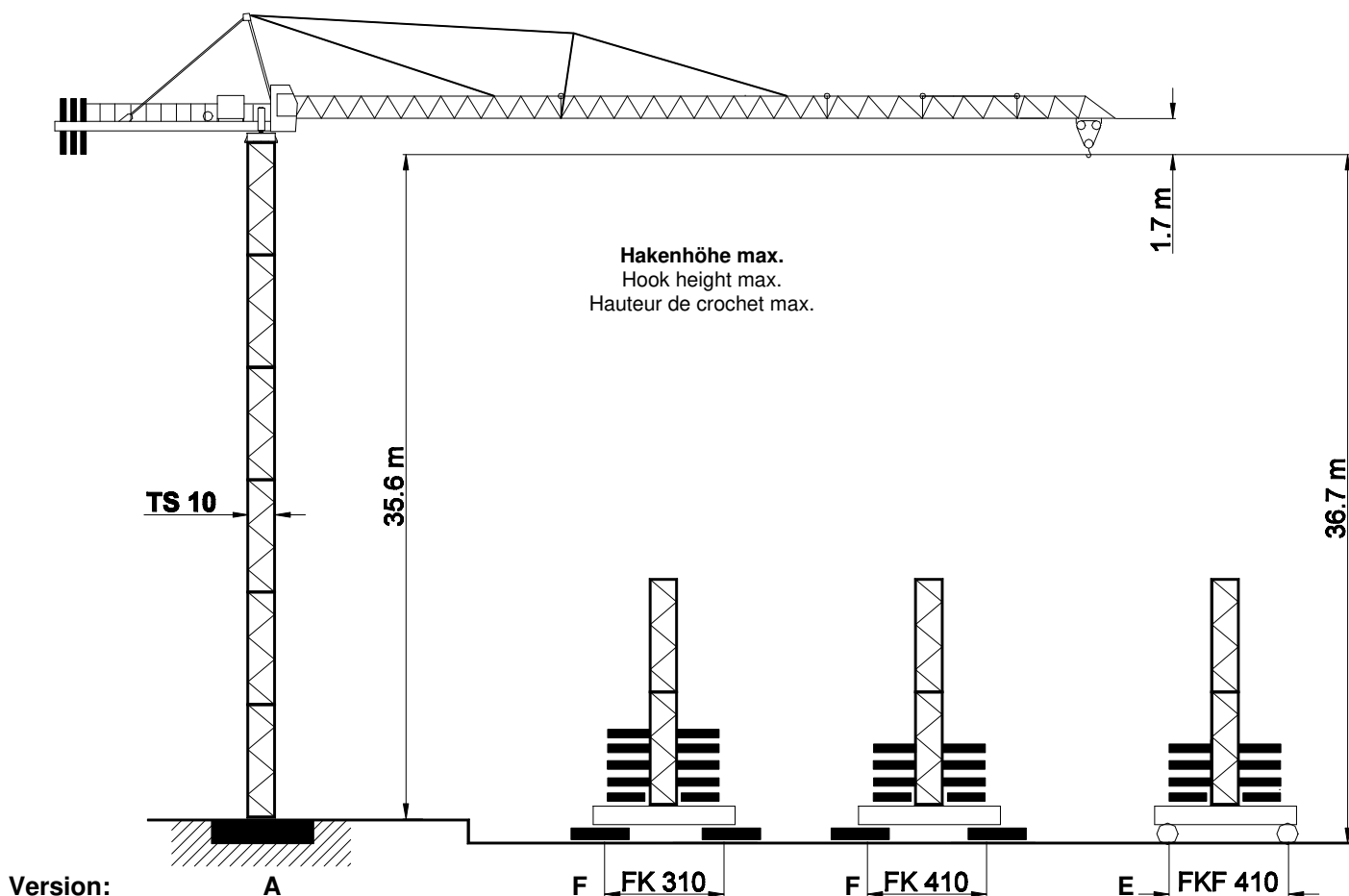

TS 10		Version A	Version F							Version E							
Turm / Tower / Tour TS 10.3	TS 10.4	HK	HK	BZ + BF t	i.B.	y	a.B.	BZ + BF t	i.B.	y	a.B.	Turm / Tower / Tour TS 10.3	TS 10.4	BZ	i.B.	y	a.B.
6.0 m	12.0 m	m	m	t	kN	kN	kN	t	kN	kN	kN	6.0 m	12.0 m	t	kN	kN	kN
6 x TS 10.3	3 x TS 10.4	35.6	36.7	70.8	444	482	50.8	366	398	1 x TSV 10.3 5 x TS 10.3	1 x TSV 10.3 2 x TS 10.4 1 x TS 10.3	50	404	402			
5 x TS 10.3		29.6	30.7	50.8	368	347	40.8	320	300	5 x TS 10.3		40	349	304			
4 x TS 10.3	2 x TS 10.4	23.6	24.7	40.8	324	261	30.8	277	222	4 x TS 10.3	2 x TS 10.4	30	298	202			
3 x TS 10.3		17.6	18.7	30.8	281	233	20.8	237	194	3 x TS 10.3		20	248	198			
2 x TS 10.3	1 x TS 10.4	11.6	12.7	30.8	252	217	20.8	223	191	2 x TS 10.3	1 x TS 10.4	20	232	195			
1 x TS 10.3		5.6	6.7	30.8	239	214	20.8	211	188	1 x TS 10.3		20	218	192			
Fundament Foundation Fondaton 5.0 x 5.0 x 1.2 m				Fundamentkreuz Cruciform base Croix de fondation							Fundamentkreuz, fahrbar Cruciform base, railgoing Croix de fondation, mobile						
Fundamentfüße Fixing angles Ancres de fondation 4 x FF 10/14				FK 310			FK 410				FKF 414						
				BF 4 x 2.7 t	BZ Block 5.0 t		BF 4 x 2.7 t	BZ Block 5.0 t		Fahrschemel / bogie gerade / straight / droite F 40/1							

TS 10.3 = 6.0 m

TS 10.4 = 12.0 m

TSV 10.3 = 6.0 m

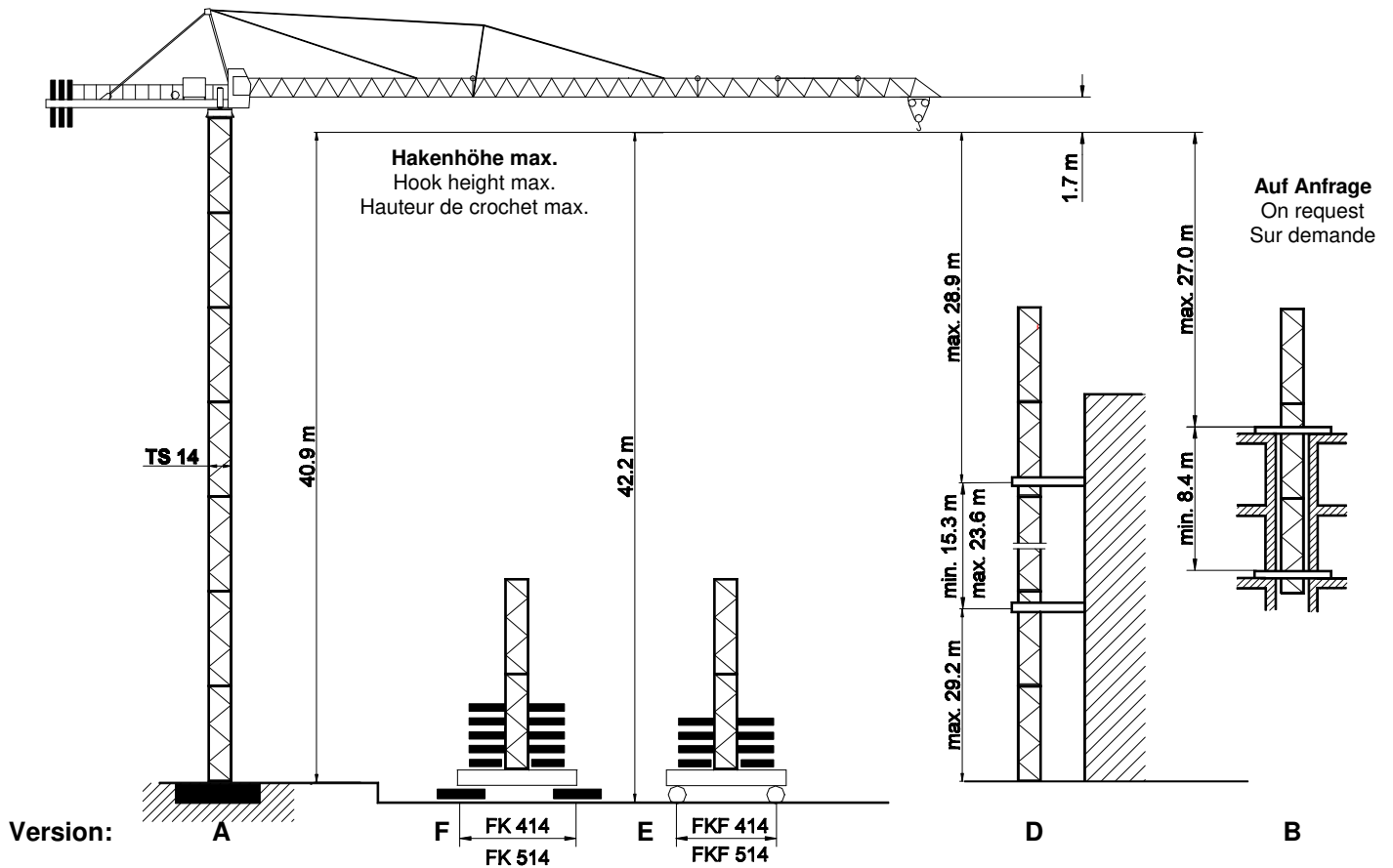

TS 14		Version A	Version F							Version E					
Turm / Tower / Tour TS 14.3	TS 14.4	HK	HK	BZ + BF t	y i.B.	a.B.	BZ + BF t	y i.B.	a.B.	BZ t	i.B. kN	a.B. kN	BZ t	i.B. kN	a.B. kN
5.9 m	11.8 m	m	m	t	kN	kN	t	kN	kN	t	kN	kN	t	kN	kN
7 x TS 14.3		40.9	42.2	70.8	446	561	53.0	371	449	70.0	489	561	42.2	385	449
6 x TS 14.3	3 x TS 14.4	35.0	36.3	60.8	398	438	43.0	327	357	60.0	433	442	32.2	334	338
5 x TS 14.3		29.1	30.4	40.8	327	319	33.0	284	276	40.0	354	323	22.2	285	257
4 x TS 14.3	2 x TS 14.4	23.2	24.5	30.8	283	234	23.0	243	202	30.0	297	237	12.2	233	183
3 x TS 14.3		17.3	18.6	20.8	241	196	10.8	198	159	20.0	252	200	12.2	216	171
2 x TS 14.3	1 x TS 14.4	11.4	12.7	20.8	226	192	10.8	184	155	20.0	235	196	12.2	201	167
1 x TS 14.3		5.5	6.8	20.8	212	188	10.8	173	152	20.0	219	192	12.2	188	164
Fundament Foundation Fondaton 5.6 x 5.6 x 1.2 m		Fundamentkreuz Cruciform base Croix de fondation							Fundamentkreuz, fahrbar Cruciform base, railgoing Croix de fondation, mobile						
Fundamentfüße Fixing angles Ancres de fondation 4 x FF 10/14		FK 414				FK 514			FKF 414			FKF 514			
		BF 4 x 2.7 t		BZ Block 5.0 t		BF 4 x 2.7 t		BZ Block 5.0 t 6.1 t		Fahrschemel / bogie gerade / straight / droite			Fahrschemel / bogie Kurve / curve / courbe		
										F 40/1			F 320		

TS 14.3 = 5.9 m

TS 14.4 = 11.8 m

SK 76

Ausladung und Tragfähigkeit / Radius and capacity / Portée et charge

Ausleger Jib Flèche	Max. Tragfähigkeit max. capacity charge max.	Ausladung (m) und Tragfähigkeit (t) Radius (m) and capacity (t) Portée (m) et charge (t)																
		16	18	20	22	24	26	28	30	33	35	38	40	41	42	43	44	45
m	5.0 t																	
L4 45.0	2.5 - 14.2 m	4.36	3.81	3.37	3.02	2.73	2.49	2.29	2.11	1.89	1.76	1.60	1.50	1.46	1.41	1.37	1.34	1.3
L3 40.0	2.5 - 15.3 m	4.75	4.15	3.68	3.30	2.99	2.73	2.50	2.31	2.07	1.93	1.75	1.65					
L2 35.0	2.5 - 16.4 m	5.00	4.49	3.99	3.58	3.24	2.96	2.72	2.51	2.25	2.10							
L1 30.0	2.5 - 16.9 m	5.00	4.65	4.12	3.70	3.35	3.06	2.81	2.60									

Geschwindigkeiten / Speeds / Vitesses

PU S 4-50/2		v = 22 / 45 m / min.	4.0 kW	400 V 50 Hz 3 Ph
SR 5-90/3		v = 0 → 25 m / min.	2 x 5.0 kW	
K SRA 75/4		v = 0 → 0.75 min ⁻¹	4.4 kW	

HK max. = 85 m 2 - Lagen / 2 - layers / 2 - couches





Type PU 15-25/3 15.0 kW			→ 52 m / min	1 500 kg		→ 26 m / min	3 000 kg	Motorenleistung ges. Total motor output Puissance moteur (ohne/without/sans SR 5-90/3) ~23 kW
			→ 26 m / min	2 500 kg		→ 13 m / min	5 000 kg	
			→ 6 m / min			→ 3 m / min		Anschlußleistung Connected power Puissance installée 40 kVA

HK max. = 85 m 2 - Lagen / 2 - layers / 2 - couches

Type FU 17-25/5 17.0 kW			<p>Traglast [t] vs Geschwindigkeit [m/min]</p>		<p>Traglast [t] vs Geschwindigkeit [m/min]</p>		Motorenleistung ges. Total motor output Puissance moteur (ohne/without/sans SR 5-90/3) ~25 kW
			Anschlußleistung Connected power Puissance installée 40 kVA				

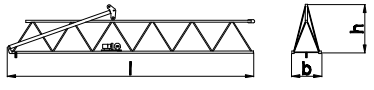
Gegengewichtsballast / Counterweight / Contrepoids

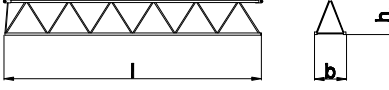
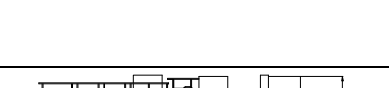
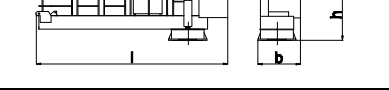
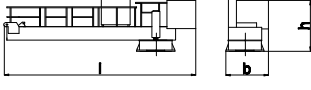
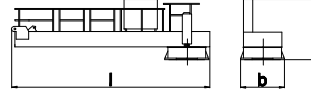
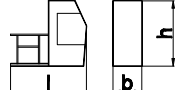
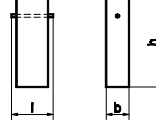
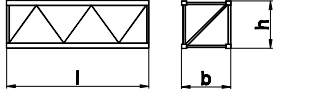
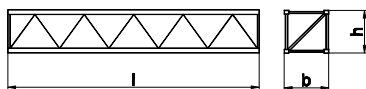
Ausleger / Jib / Flèche		L 1	L 2	L 3	L 4
Gegengewicht	BG	7 500 kg	8 150 kg	8 800 kg	9 450 kg
Counterweight	[t]	3 x 2.50	2 x 2.50	1 x 2.50	
Contrepoids			1 x 3.15	2 x 3.15	3 x 3.15

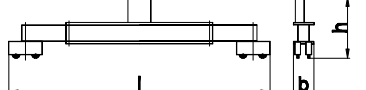
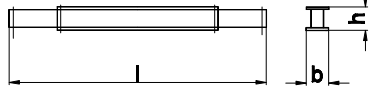
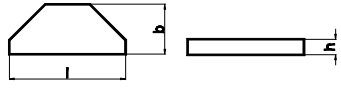
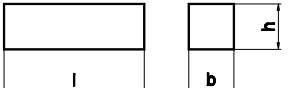
	Benennung Designation Désignation		Abmessungen (m / ft) Dimensions (m / ft)			Gewicht t Weight Poids t / kips	Volumen Volume m ³ / ft ³	
			l	b	h			
1	Ausleger / Jib / Flèche Schuss / Section / Élément I		15.25	1.05	1.23	1.90	24.0	
			50.03	3.45	4.03	4.2	849	
	Schuss / Section / Élément II		14.43	0.94	1.20	0.96	16.3	
			47.34	3.08	3.94	2.1	574	
2	Ausleger / Jib / Flèche Schuss / Section / Élément IV		5.15	0.94	0.94	0.25	4.5	
			16.90	3.08	3.08	0.55	160	
			5.15	0.94	0.94	0.20	4.5	
	Schuss / Section / Élément V		16.90	3.08	3.08	0.44	160	
			5.15	0.94	0.94	0.25	4.5	
	Schuss / Section / Élément VI		16.90	3.08	3.08	0.55	160	
3	Drehbühne mit Drehkranzauflage u. Kabine Turntable with slewing ring support and cabin Plateforme tournante avec support de couronne d'orientation et cabine		12.61	2.40	2.30	6.78	69.6	
			41.37	7.87	7.55	14.95	2458	
4	Drehbühne mit Drehkranzauflage Turntable with slewing ring support Plateforme tournante avec support couronne d'orientation		11.36	1.77	2.04	4.76	41.0	
			37.27	5.81	6.69	10.49	1449	
5	Kabine mit Podest und Geländer Cabin with support and railing Cabine avec appui et garde corps		2.65	2.21	1.30	0.50	7.6	
			8.69	7.25	4.26	1.10	268	
6	Gegengewichtsballast Counter jib ballast Contrepoids		BG 3.15 t	1.20	0.50	2.84	3.15	1.4
			2.50 t	3.94	1.64	9.32	6.95	60
				1.20	0.50	2.29	2.50	1.2
				3.94	1.64	7.5	5.5	51
7	Turmschuss Tower section Élément de tour		TS 10.3	6.00	1.25	1.25	1.35	9.38
			TSV 10.3	19.69	4.10	4.10	2.98	355
			TS 14.3	6.00	1.25	1.25	1.50	9.38
				19.69	4.10	4.10	3.31	355
				5.91	1.60	1.61	1.45	15.22
				19.39	5.25	5.28	3.20	538
	TS 10.4		12.00	1.25	1.25	2.60	18.75	
			39.37	4.10	4.10	5.73	662	
			11.80	1.60	1.61	2.70	30.40	
	TS 14.4		38.71	5.25	5.28	5.95	1073	
8	Fundamentkreuz, fahrbar, geklappt Movable undercarriage, folded Châssis roulant, replié		FKF 410/414	6.80	2.20	1.62	5.70	24.2
			514	22.31	7.22	5.32	12.57	857
			8.25	2.40	1.67	7.40	33.07	
			27.07	7.87	5.48	24.28	1167	
9	Fundamentkreuz, stationär, geklappt Stationary undercarriage, folded Châssis fixe, replié		FK 310	5.74	0.95	0.90	3.25	4.91
			410/414	18.83	3.12	2.95	7.16	173
			514	6.04	1.68	0.81	3.40	8.22
				19.82	5.51	2.66	7.50	290
			7.55	1.50	1.01	4.90	11.44	
			24.77	4.92	3.31	16.08	403	
10	Zentralballaststein Central ballast block Bloc de fondation		BZ 6.1 t	4.00	1.35	0.65	6.10	3.5
			5.0 t	13.12	4.43	2.13	13.45	124
				3.50	1.50	0.67	5.00	3.5
			11.48	4.92	2.20	11.24	124	
11	Fundamentblock Foundation pad Bloc de fondation		2.80	0.70	0.55	2.70	1.08	
			9.19	2.30	1.80	5.95	38	
12	Diverse Montageteile Accessories Accessoires							