

GP matic 36

  EN 14439

10/40

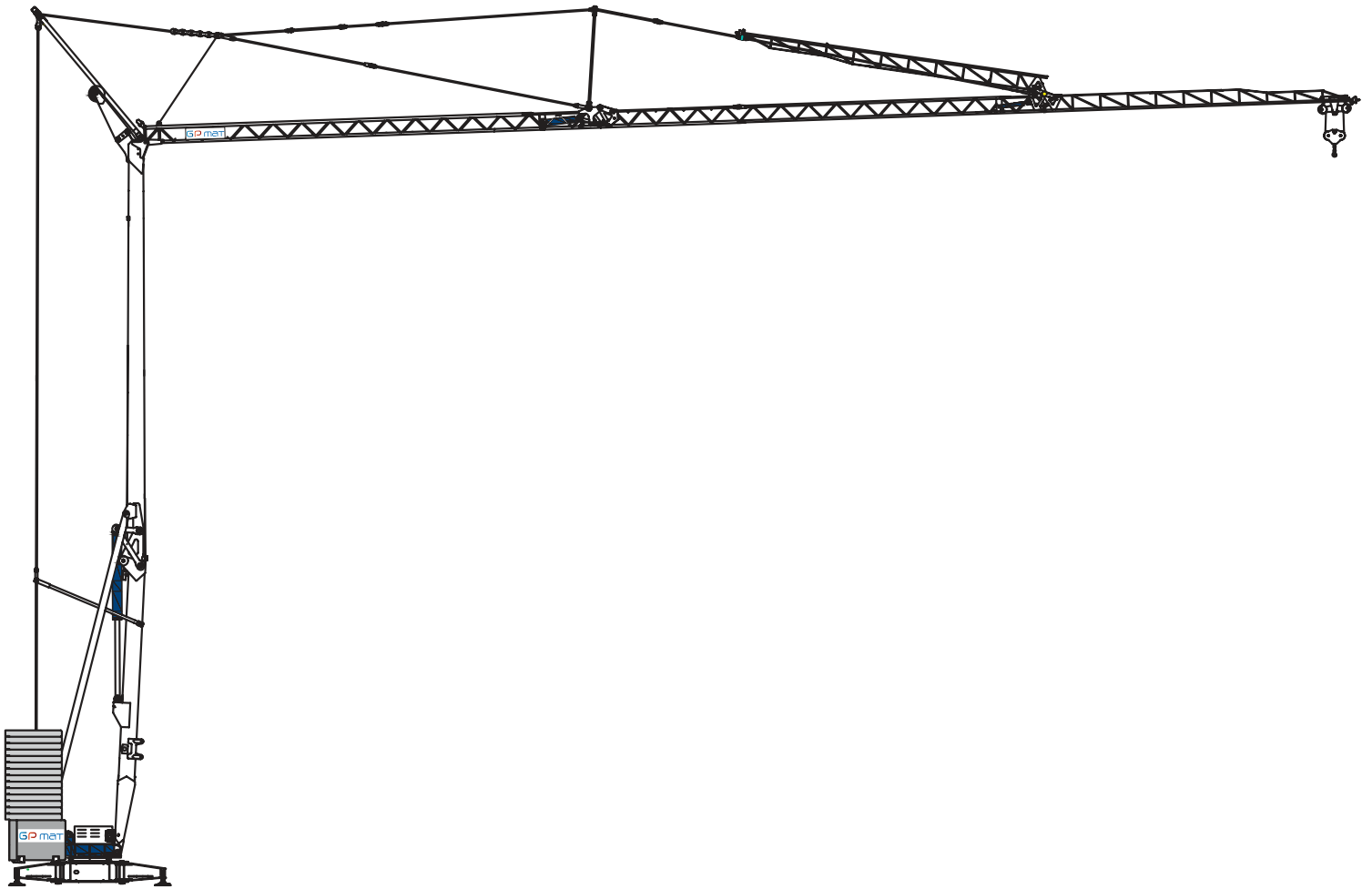

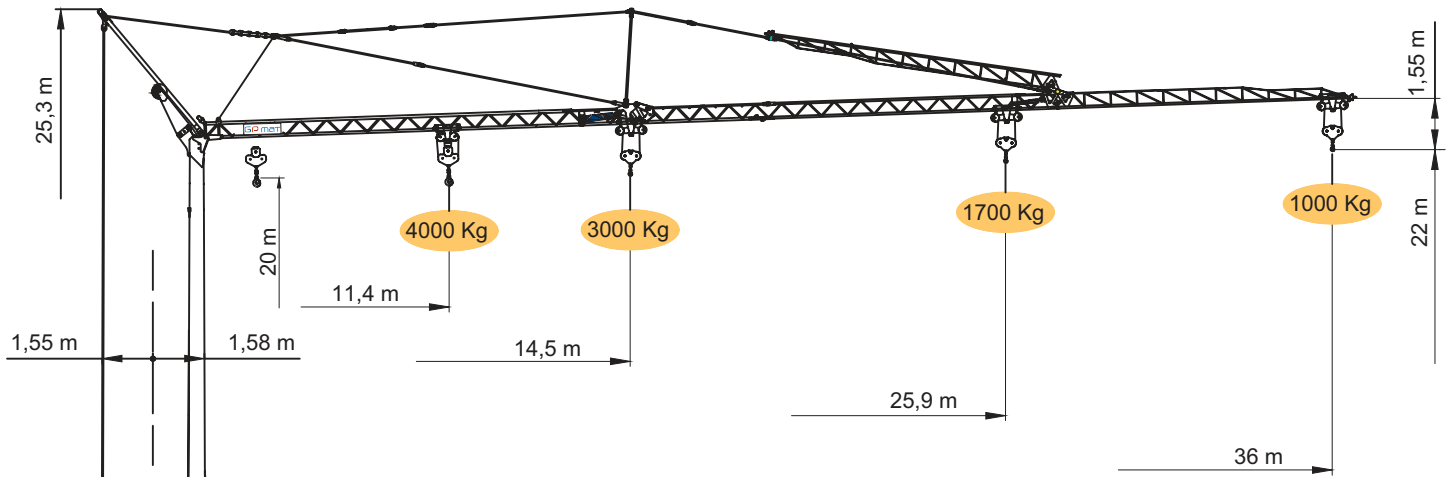
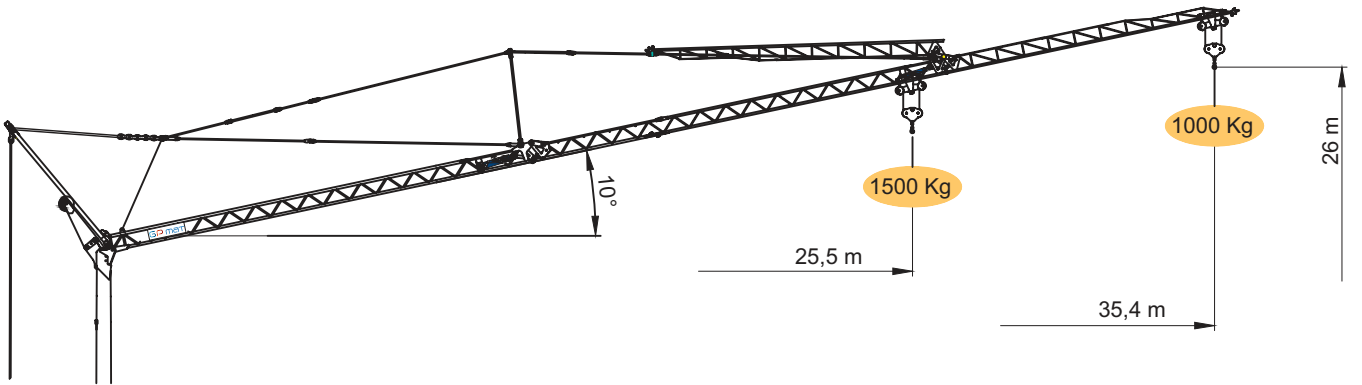
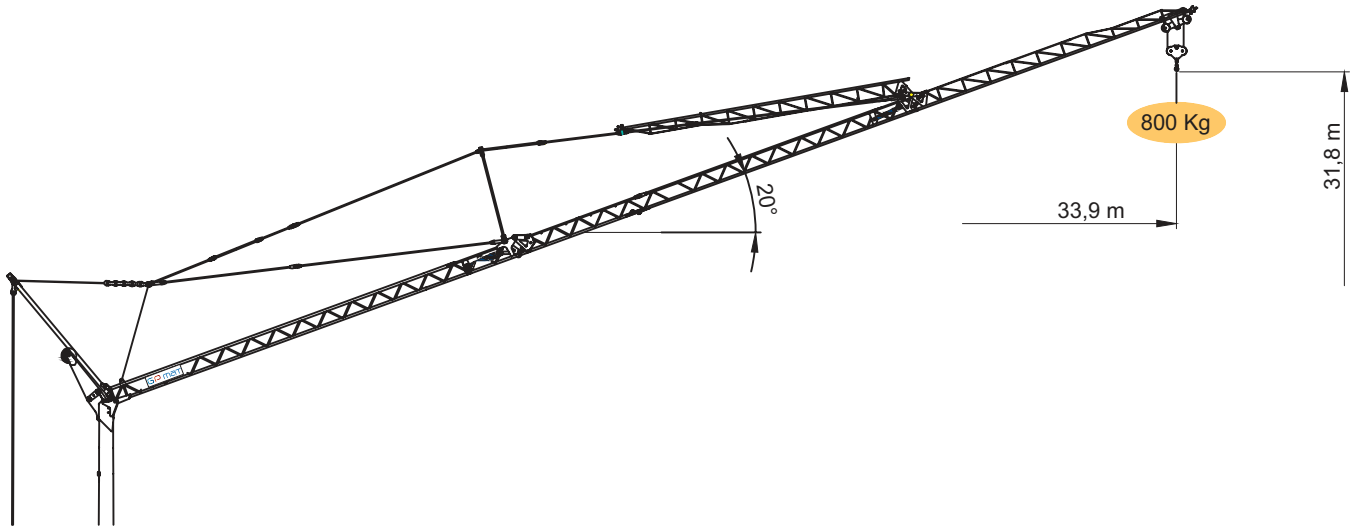

kg	3000	2670	2320	2046	1825	1644	1493	1364	1254	1158	1074	1000
m	14,5	16	18	20	22	24	26	28	30	32	34	36

kg	4000	3776	3134	2670	2320	2046	1825	1644	1493	1364	1254	1158	1074	1000
m	11,4	12	14	16	18	20	22	24	26	28	30	32	34	36

DOTAZIONE DI SERIE

Sollevamento, rotazione e carrello a tre velocità con inverter, zincatura della struttura e dei tiranti, contrapeso, braccio impennabile, carrello rampante con motore e finecorsa alla base della torre, funzionamento con braccio ripiegato, comando a pulsantiera via cavo, carter di protezione per ralla e meccanismi, predisposizione per autozavorramento e radiocomando, armadio elettrico in acciaio inox, documentazione a norme CEE.

STANDARD FEATURES

3-speed lifting, rotation and trolley with inverter control, galvanised structure, counterweight, pull-up jib, translation trolley with motor and limit switch at base of gantry, operation with folden jib, cable-operated pushbutton remote control, guard for slewing ring and mechanisms, designed to allow installation of self-ballasting device and radio-control, stainless steel electrical cabinet, documentation in accordance with EU standards.

EQUIPEMENT DE SERIE

Levage, chariot et rotation à trois vitesses à contrôle électronique, galvanisation de la structure et des tirants, contrepoids, flèche relevable, moteur de chariot et fin de course à la base de la tour, fonctionnement bras replié, commande par câble, carter de protection pour la couronne et les mécanismes, prédisposition pour autolestage et commande radio, armoire électrique en acier inox, documentation conforme aux normes CEE.

SERIENAUSSTATTUNG

Heben, Laufkatze und Rotation mit drei Geschwindigkeiten, Strukturverzinkung, Gegengewicht, hochklappbarer Arm, aufsteigender Wagen mit Motor und Anschlag an der Basis des Turms, Funktionieren mit eingeklapptem Arm, Steuerung mit Druckknopfplatte via kabel, Schutzvorrichtungen für Drehverbindungen und Mechanismen, vorbereitung für Selbstballasteinahme und Funksteuerung, elektrischer Schrank aus rostfreiem Stahl, Dokumentation gemäß EC Vorschriften.

DOTACION DE SERIE

Levantamiento, carro y rotación a tres velocidades con control electrónico, galvanización de la estructura, contrapeso, brazo epinable, carro rampante con motor y fin de carrera en la base de la torre, funcionamiento con brazo replgado, funcionamiento por pulsadores via cable, carter de protección para corona de giro y mecanismos, predisposición para autocontrapeso y radiocomando, armario eléctrico de acero inox, documentación según normas CEE.

	400V (±10%) 50 Hz		12kVA		
	m/l'	6	20	42	50
	kg	3000	3000	1200	800
	kW	11 (Inverter)			
	m/l'	6 - 3*	20 - 10*	42 - 21*	50 - 25*
	kg	2000 - 4000*	2000 - 4000*	1200 - 2400*	800 - 1600*
	kW	11 (Inverter)			
	m/l'	16	26	48.7 (x 35.7)	
	kW	3 (Inverter)			
	n/l'	0.17	0.43	0.85	
	n/l'	0.17		0.43	
	kW	3 (Inverter)			
	min	18		15.500 kg	
	kW	3			
	8000 kg	4000 kg	0 kg		
P1	9838 kg * 10700 kg 11460 kg **	6638 kg * 7450 kg 8165 kg **	3439 kg * 4200 kg 4871 kg **		
P2	13662 kg * 12800 kg 12040 kg **	12862 kg * 12050 kg 11335 kg **	12061 kg * 11300 kg 10629 kg **		

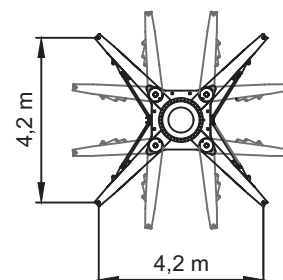
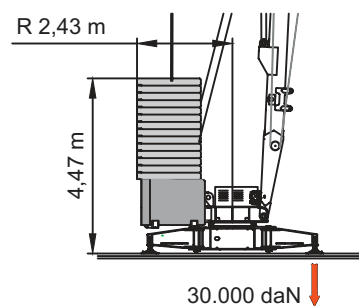
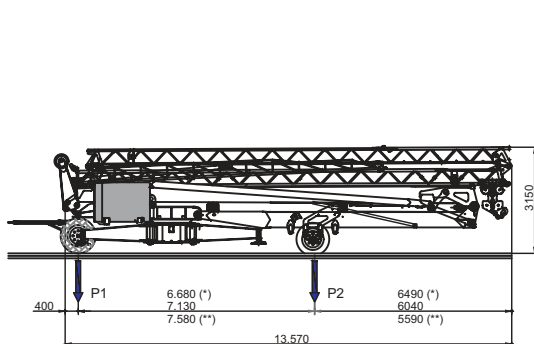

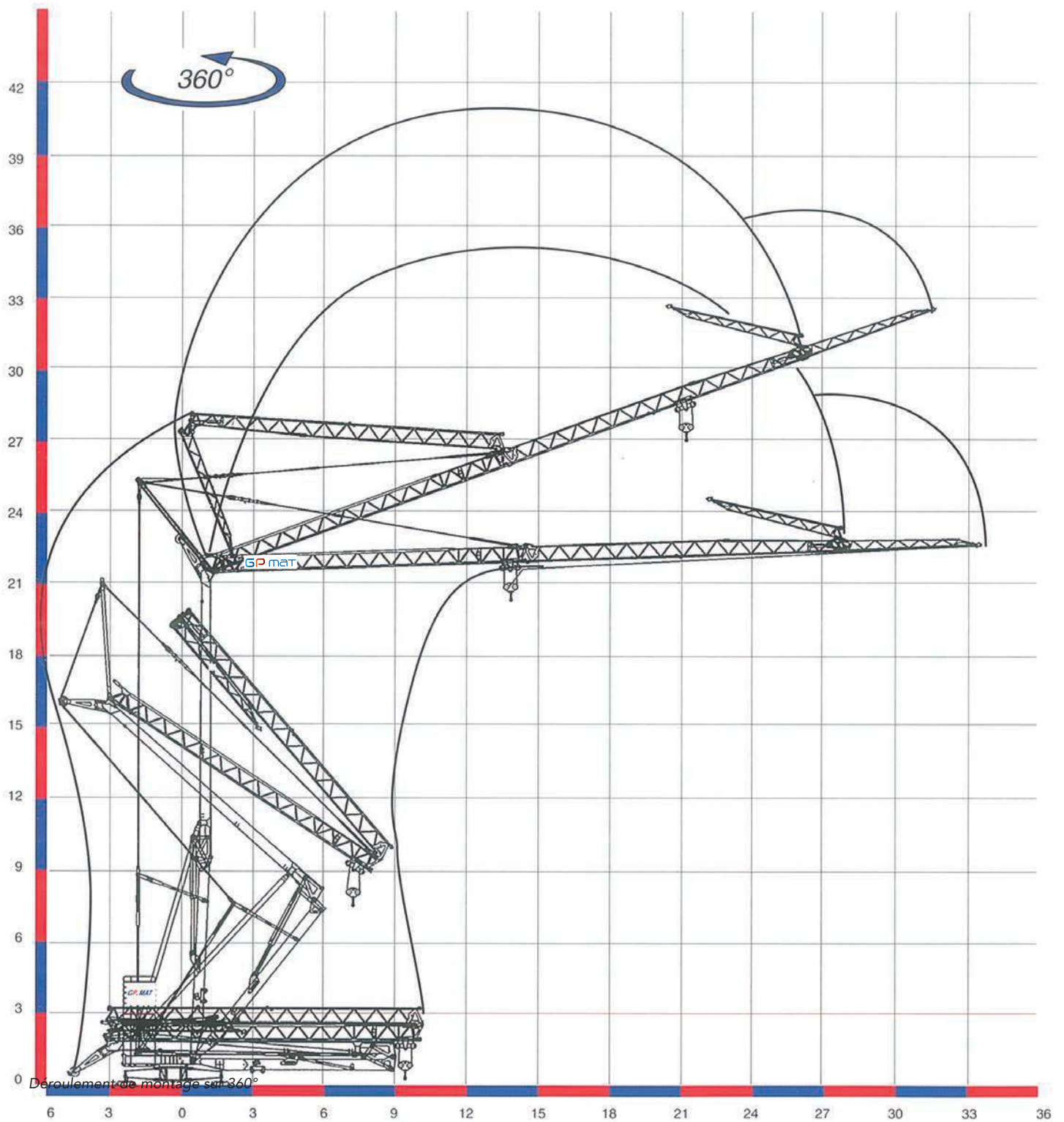

NANTES

Z.A. de la Forêt
44140 LE BIGNON
 Tél. 02 40 78 10 10 - Fax 02 40 78 11 00

AVIGNON

233 Chemin du Bac de Bompas
84270 VEDENE
 Tél. 04 90 48 00 48 - Fax 04 90 48 00 00

contact@gpmat.fr - www.gpmat.fr

Filiales : GP MAT OCÉAN INDIEN, GP MAT MARTINIQUE

