

TM-ZR500XL



MAXIMUM LIFTING CAPACITY: 10,000 lbs
EXTENDED LENGTH: 51.4' (TM-ZR506XL)

Telescoping boom truck mounted crane
Known World Wide, TADANO Quality in North America

TM-ZR500XL series (5ton) crane specifications

MAXIMUM LIFTING CAPACITY

10,000 lbs. @ 5' (5-part lines) (TM-ZR505XL & TM-506XL need extra sheeve exchange hook block for 10,000 lbs capacity)

BOOM

Fully powered synchronized telescoping boom of pentagonal box construction

Sections	3(TM-ZR503XL), 4(TM-ZR504XL), 5(TM-ZR505XL), 6(TM-ZR506XL)
Retracted length	11.40'(TM-ZR503XL), 11.66'(TM-ZR504XL), 12.38'(TM-ZR505XL), 12.64'(TM-ZR506XL)
Extended length	27.28'(TM-ZR503XL), 35.43'(TM-ZR504XL), 43.78'(TM-ZR505XL), 51.49'(TM-ZR506XL)
Extended speed	15.88' / 18 s(TM-ZR503XL), 23.77' / 21 s(TM-ZR504XL), 31.40' / 25 s(TM-ZR505XL), 38.85' / 28 s(TM-ZR506XL)
Elevation	Elevated by double-acting hydraulic cylinder
Elevation speed	1° to 78° / 12 s

NOTE: Extended speed and elevation speed are calculated under the condition that the flow is 25 GPM

Boom point 3 sheaves(TM-ZR503XL)(TM-ZR504XL), 2 sheaves(TM-ZR505XL)(TM-ZR506XL)

WINCH

Hydraulic motor driven, Spur gear speed reduction, provided with mechanical brake and cable follower

Single line pull	2,000 lbs. (TM-ZR503XL)(TM-ZR504XL), 1,750 lbs. (TM-ZR505XL)(TM-ZR506XL)
Single line speed	249FPM (@4th layer)

NOTE: Single line speed is calculated under the condition that the flow is 57 GPM

Wire rope

Diameter x length	5/16" x 217' (TM-ZR503XL), 5/16" x 262' (TM-ZR504XL)(TM-ZR505XL), 5/16" x 302' (TM-ZR506XL)
-------------------	---

Breaking strength	9,680 lbs.
Construction	7 x 7 + 6 x WS(26)

Hook block 2 sheaves

SWING

Hydraulic motor driven, Worm gear speed reduction, Continuous 360° full circle swing on ball bearing slew ring, Automatic swing lock

Swing speed approx. 2.5 rpm

HOOK STOWING DEVICE

Mechanically stowed beneath boom top portion

OUTRIGGERS

Manually extended sliders and hydraulically extended jacks, Integral with crane frame, Power up and down Easy grab type grips lock and unlock sliders position and double lock pins for storage position.

Extended width	Min. 7' 2-5/8" Mid. 9' 10-1/8" Max. 12' 5-19/32"
----------------	--

NOTE: Max. operating speeds of the crane are performed under the condition that the pump delivery is 15.8 GPM.

TM-ZR500XL series crane dimensional specifications

TM-ZR506XL

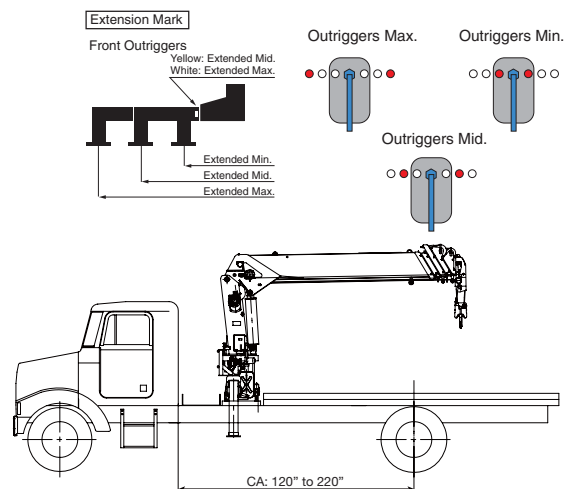
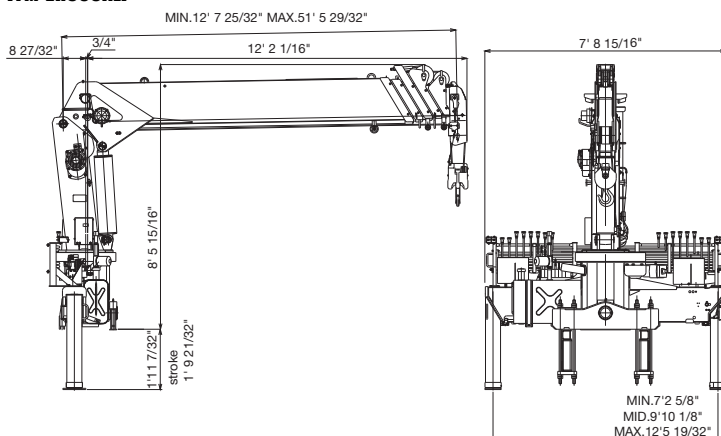

(This dimension depends on jack floats applied.)

HYDRAULIC

Hydraulic motor	Axial piston type for winch and swing
Control valves	Multiple control valves with integral safety valve
Recommended Hydraulic pump	Pressure : Max. 2,915 PSI capacity Delivery : Max. 15.8 GPM capacity

ELECTRICAL SYSTEM

Power supply	DC12V
--------------	-------

SAFETY DEVICE

- Anti-two-block with alarm
 - Hook safety latch
 - Level gauge
 - Hydraulic safety valves, check valves and holding valves
 - Over load alert with load indicator (TADANO's exclusive "AMA" system)
 - Load indication
 - Load moment ratio to rated load indication
 - Audible warning
 - External warning lamps
-

CRANE WEIGHT

- Approx. 3,330 lbs. (TM-ZR503XL / crane bare)
 - Approx. 3,590 lbs. (TM-ZR504XL / crane bare)
 - Approx. 3,950 lbs. (TM-ZR505XL / crane bare)
 - Approx. 4,150 lbs. (TM-ZR506XL / crane bare)
-

OPTIONS AND ACCESSORIES

+Radio Remote Controls

Model : RCS-F (Approved by FCC/IC)

Control function of boom telescoping, hoisting up and down, boom elevating, swing, acceleration, speed mode selection, emergency stop, engine start and vehicle horn

Frequency 40 frequencies in 429 MHz band

Operating power supply

Transmitter 6V DC, dry battery (AA) x 4

Control unit 12V DC, vehicle battery

Transmitter weight

Approx. 1.26 lbs. (includes batteries)

+One person basket

(Only for TM-ZR505XL with Radio Remote: Serial number sensitive.)

300 lbs capacity, steel, non-rotation, painted blue, no- harness included.

Cage outside dimensions; L x W x H: 30" x 30" x 42". Weight: 390 lbs

+10,000 lbs capacity hook block & extra sheave for TM-ZR505XL & TM-ZR506XL.

(TM-ZR503XL & TM-ZR504XL as standard)



TM-ZR505XL with Radio Remote only



Hook Stowing



TM-ZR506XL

TM-ZR500XL series [5ton] crane capacity

WORKING RANGE CHART TM-ZR503XL

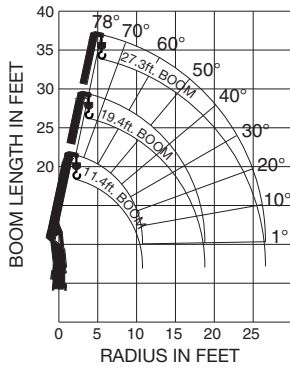

TM-ZR504XL

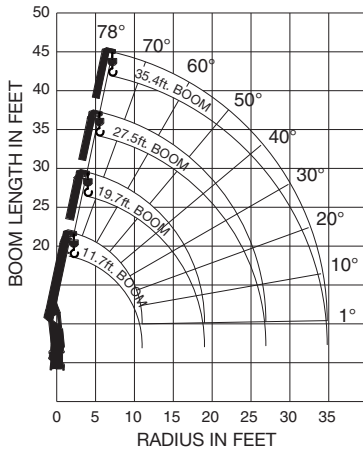

TM-ZR505XL

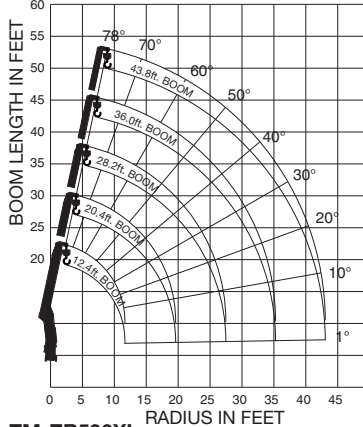

TM-ZR506XL

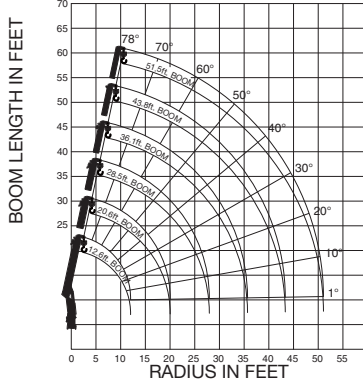

The above lifting heights and boom angles are based on a straight (unladen) boom, and allowance should be made for boom deflection obtained under laden condition.

RATED LIFTING CAPACITIES (IN POUNDS) MODEL : TM-ZR503XL CAPACITY CHART ; A

Load Radius (ft)	11.4 ft Boom			19.4 ft Boom			27.2 ft Boom		
	Loaded Boom Angle	Outriggers Extended		Loaded Boom Angle	Outriggers Extended		Loaded Boom Angle	Outriggers Extended	
		Max.	Min.		Max.	Min.		Max.	Min.
5	63	10,000	7,000	76	10,000	7,000			
6	57	9,700	6,000	73	9,700	6,000			
8	44	8,800	4,500	67	8,800	4,500	75	7,000	4,500
10	24	6,800	3,400	60	6,800	3,400	70	6,800	3,400
12				52	5,200	2,600	66	5,200	2,600
14				44	4,000	2,000	61	4,000	2,000
16				34	3,100	1,550	56	3,100	1,550
20							44	2,200	1,100
25							23	1,600	800
	1°	6,200	3,100	1°	2,500	1,250	1°	1,500	750
		(10.7ft)			(18.7ft)			(26.6ft.)	

MODEL : TM-ZR504XL CAPACITY CHART ; A

Load Radius (ft)	11.7 ft Boom			19.7 ft Boom			27.5 ft Boom			35.4 ft Boom		
	Loaded Boom Angle	Outriggers Extended		Loaded Boom Angle	Outriggers Extended		Loaded Boom Angle	Outriggers Extended		Loaded Boom Angle	Outriggers Extended	
		Max.	Min.		Max.	Min.		Max.	Min.		Max.	Min.
5	64	10,000	7,000	76	10,000	7,000						
6	58	9,700	6,000	73	9,700	6,000	78	7,000	6,000			
8	45	8,800	4,500	67	8,800	4,500	75	7,000	4,500	78	4,400	4,400
10	27	6,800	3,400	60	6,800	3,400	71	6,800	3,400	76	4,400	3,400
12				53	5,200	2,600	66	5,200	2,600	73	4,400	2,600
14				45	4,000	2,000	61	4,000	2,000	69	4,000	2,000
16				35	3,100	1,550	56	3,100	1,550	66	3,100	1,550
20							45	2,200	1,100	58	2,200	1,100
25							25	1,550	750	47	1,550	750
30										34	1,150	550
	1°	6,000	3,000	1°	2,400	1,200	1°	1,400	650	1°	900	400
		(10.9ft)			(18.9ft)			(26.8ft)			(34.7ft)	

MODEL : TM-ZR505XL CAPACITY CHART ; A

Load Radius (ft)	12.4 ft Boom			20.4 ft Boom			28.2 ft Boom			36.0 ft Boom		43.7 ft Boom			
	Loaded Boom Angle	Outriggers Extended		Loaded Boom Angle	Outriggers Extended		Loaded Boom Angle	Outriggers Extended		Loaded Boom Angle	Outriggers Extended	Loaded Boom Angle	Outriggers Extended		
		Max.	Min.		Max.	Min.		Max.	Min.					Max.	Min.
5	66	10,000	7,000	76	7,000	7,000									
8	49	7,000	4,500	67	7,000	4,500	75	7,000	4,500	78	4,400				
10	33	6,800	3,400	61	6,800	3,400	71	6,800	3,400	75	4,400	78	2,900		
12				54	5,200	2,500	66	5,200	2,500	72	4,400	76	2,900		
14				47	3,900	1,900	62	3,900	1,900	69	3,900	73	2,900		
16				38	3,000	1,450	57	3,000	1,450	66	3,000	71	2,900		
20							46	2,000	950	58	2,000	65	2,000		
25							27	1,350	600	47	1,350	57	1,350		
30										34	1,050	49	1,050		
35												38	850		
40												25	700		
	1°	5,500	2,700	1°	2,100	1,000	1°	1,200	500	1°	800	1°	600		
		(11.7ft)			(19.7ft)			(27.5ft)			(35.3ft)			(43.1ft)	

MODEL : TM-ZR506XL CAPACITY CHART ; A

Load Radius (ft)	12.7 ft Boom			20.6 ft Boom			28.5 ft Boom			36.1 ft Boom		43.8 ft Boom		51.4 ft Boom				
	Loaded Boom Angle	Outriggers Extended		Loaded Boom Angle	Outriggers Extended		Loaded Boom Angle	Outriggers Extended		Loaded Boom Angle	Outriggers Extended	Loaded Boom Angle	Outriggers Extended	Loaded Boom Angle	Outriggers Extended			
		Max.	Min.		Max.	Min.		Max.	Min.							Max.	Min.	
5	67	10,000	7,000	77	7,000	7,000												
8	50	7,000	4,500	68	7,000	4,500	75	7,000	4,500	78	4,400							
10	36	6,800	3,400	62	6,800	3,400	71	6,800	3,400	75	4,400	78	2,900					
12				55	5,100	2,400	67	5,100	2,400	72	4,400	76	2,900	78	1,100			
14				48	3,800	1,800	62	3,800	1,800	69	3,800	73	2,900	76	1,100			
16				39	3,000	1,400	57	3,000	1,400	66	3,000	71	2,900	73	1,100			
20							46	2,000	900	58	2,000	65	2,000	69	1,100			
25							28	1,300	550	48	1,300	57	1,300	63	900			
30										35	1,000	49	1,000	56	800			
35												38	750	49	700			
40												25	600	40	550			
45														30	450			
50																		
		5,200	2,500		2,000	900		1,150	400		700		500		350			
		(11.9ft)			(19.9ft)			(27.7ft)			(35.4ft)			(43.1ft)			(50.8ft)	

MODEL : TM-ZR503XL
CAPACITY CHART ; D (Bigger stability)

Load Radius (ft)	11.4 ft Boom			19.4 ft Boom			27.2 ft Boom		
	Loaded Boom Angle	Outriggers Extended		Loaded Boom Angle	Outriggers Extended		Loaded Boom Angle	Outriggers Extended	
		Max.	Min.		Max.	Min.		Max.	Min.
5	63	10,000	7,000	76	10,000	7,000			
6	57	9,700	7,000	73	9,700	7,000			
8	44	9,100	6,800	67	9,100	6,800	75	7,000	6,800
10	24	8,500	5,400	60	8,500	5,400	70	7,000	5,400
12				52	7,100	4,100	66	6,500	4,100
14				44	6,000	3,300	61	5,700	3,300
16				34	5,100	2,800	56	5,000	2,800
20							44	3,900	2,000
25							23	3,000	1,550
	1°	8,100	5,000	1°	4,300	2,300	1°	2,700	1,450
		(10.7ft)			(18.7ft)			(26.6ft.)	

NOTE :

- Rated lifting capacities on this chart show maximum allowable loads with the outriggers properly extended on a firm surface and the crane leveled and mounted on a factory recommended truck. The rated lifting capacities in shade area are based on crane strength and others, on its stability(not to exceed 85% of tipping).
- The weight of handling devices such as hook block (65lbs.), slings, etc., must be considered part of the load and must be deducted from the rated lifting capacities.
- The operator must reduce loads to allow for such factors as wind, ground conditions, operating speed and the effects of freely suspended loads such as boom deflection.
- For boom lengths not shown, use the rated lifting capacity of next longer boom.
- When outriggers are extended to mid.position, use the rated lifting capacities for outriggers extended to min. position.

MODEL : TM-ZR504XL
CAPACITY CHART ; D (Bigger stability)

Load Radius (ft)	11.7 ft Boom			19.7 ft Boom			27.5 ft Boom			35.4 ft Boom		
	Loaded Boom Angle	Outriggers Extended		Loaded Boom Angle	Outriggers Extended		Loaded Boom Angle	Outriggers Extended		Loaded Boom Angle	Outriggers Extended	
		Max.	Min.		Max.	Min.		Max.	Min.		Max.	Min.
5	64	10,000	7,000	76	10,000	7,000						
6	58	9,700	7,000	73	9,700	7,000	78	7,000	7,000			
8	45	9,100	6,800	67	9,100	6,800	75	7,000	6,800	78	4,400	4,400
10	27	8,500	5,400	60	8,500	5,400	71	7,000	5,400	76	4,400	4,400
12				53	7,100	4,100	66	6,500	4,100	73	4,400	4,100
14				45	6,000	3,300	61	5,700	3,300	69	4,400	3,300
16				35	5,100	2,800	56	5,000	2,800	66	4,100	2,800
20							45	3,900	1,950	58	3,200	1,950
25							25	3,000	1,500	47	2,400	1,500
30										34	2,000	1,150
	1°	7,900	4,800	1°	4,200	2,200	1°	2,700	1,350	1°	1,750	900
		(10.9ft)			(18.9ft)			(26.8ft)			(34.7ft)	

MODEL : TM-ZR505XL
CAPACITY CHART ; D (Bigger stability)

Load Radius (ft)	12.4 ft Boom			20.4 ft Boom			28.2 ft Boom			36.0 ft Boom		43.7 ft Boom	
	Loaded Boom Angle	Outriggers Extended		Loaded Boom Angle	Outriggers Extended		Loaded Boom Angle	Outriggers Extended		Loaded Boom Angle	Outriggers Extended Max.	Loaded Boom Angle	Outriggers Extended Max.
		Max.	Min.		Max.	Min.		Max.	Min.				
5	66	10,000	7,000	76	7,000	7,000							
8	49	7,000	6,800	67	7,000	6,800	75	7,000	6,800	78	4,400		
10	33	7,000	5,400	61	7,000	5,400	71	7,000	5,400	75	4,400	78	2,900
12				54	6,800	3,900	66	6,500	3,900	72	4,400	76	2,900
14				47	5,700	3,100	62	5,700	3,100	69	4,400	73	2,900
16				38	4,800	2,600	57	4,800	2,600	66	4,100	71	2,900
20							46	3,500	1,800	58	3,200	65	2,400
25							27	2,600	1,350	47	2,400	57	1,900
30										34	1,900	49	1,550
35												38	1,350
40												25	1,150
	1°	6,800	4,200	1°	3,600	1,850	1°	2,300	1,150	1°	1,600	1°	1,100
		(11.7ft)			(19.7ft)			(27.5ft)			(35.3ft)		(43.1ft)

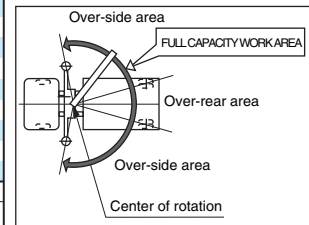

MODEL : TM-ZR506XL
CAPACITY CHART ; D (Bigger stability)

Load Radius (ft)	12.7 ft Boom			20.6 ft Boom			28.5 ft Boom			36.1 ft Boom		43.8 ft Boom		51.4 ft Boom	
	Loaded Boom Angle	Outriggers Extended		Loaded Boom Angle	Outriggers Extended		Loaded Boom Angle	Outriggers Extended		Loaded Boom Angle	Outriggers Extended Max.	Loaded Boom Angle	Outriggers Extended Max.	Loaded Boom Angle	Outriggers Extended Max.
		Max.	Min.		Max.	Min.		Max.	Min.						
5	67	10,000	7,000	77	7,000	7,000									
8	50	7,000	6,800	68	7,000	6,800	75	7,000	6,800	78	4,400				
10	36	7,000	5,400	62	7,000	5,400	71	7,000	5,400	75	4,400	78	2,900		
12				55	6,800	3,900	67	6,500	3,900	72	4,400	76	2,900	78	1,100
14				48	5,700	3,100	62	5,700	3,100	69	4,400	73	2,900	76	1,100
16				39	4,800	2,600	57	4,800	2,600	66	4,100	71	2,900	73	1,100
20							46	3,500	1,750	58	3,200	65	2,400	69	1,100
25							28	2,600	1,300	48	2,400	57	1,900	63	900
30										35	1,900	49	1,550	56	800
35												38	1,350	49	700
40												25	1,150	40	600
45														30	550
50															
	1°	6,800	4,000	1°	3,500	1,800	1°	2,200	1,100	1°	1,600	1°	1,100	1°	500
		(11.9ft)			(19.9ft)			(27.7ft)			(35.4ft)		(43.1ft)		(50.8ft)

GENERAL DATA FOR SUITABLE TRUCKS

	CAPACITY; A	CAPACITY; D
Gross Axle Weight Rating(GAWR),front	9,000 lbs. or more	12,000 lbs. or more
Gross Axle Weight Rating(GAWR),rear	17,000 lbs. or more	21,000 lbs. or more
Gross vehicle weight	26,000 to 55,100 lbs.	33,000 to 55,100 lbs.
Cab to Axle / trunnion (CA/CT)	120 to 220"	
Frame Section Modulus(SM)	10 cu. inch	110,000psi
under crane; (Total of both sides.)	22 cu. inch	50,000psi
P.T.O. torque	115 ft-lbs. Min.	
P.T.O. revolution	Approx. 270 to 2800 rpm	
Width for crane mounting	Approx. 2' 5-1/2" min.	
Frame width range (inside to outside)	Approx. 2' to 3' 1-7/8"	
Frame height (ground to frame top)	Approx. 3' 9" max.	

(Height of crane mounting base can be changed by combination of jack floats and crane bases)



Highest Quality Boom Trucks on the Planet

Continuing technical development requires Tadano to retain the right to make specifications, equipment and price changes without notice.

*Some specifications are subject to change



TADANO AMERICA CORPORATION

4242 WEST GREENS ROAD
HOUSTON, TEXAS 77066 U.S.A.

PHONE: (281) 869-0030

FAX: (281) 869-0040

Parts Hotline: (281) 869-0033

Service Hotline: (281) 869-5925

Web site: <http://www.tadanoamerica.com>

E-mail: sales@tadano-cranes.com



Lifting your dreams

TMZR500XL-2009-01-1