

GRUA TORRE TOWER CRANE

J85

UNE 58-101-92
FEM 1001-87
Directivas de nivel de potencia acústica / Sound power level directives
84/534/CEE & 87/405/CEE
Directivas de máquinas / Machinery directives
89/392/CEE & 91/368/CEE

SISTEMA DE CALIDAD CERTIFICADO SEGUN
QUALITY ASSURANCE SYSTEM CERTIFIED ACCORDING TO
UNE-EN-ISO 9001

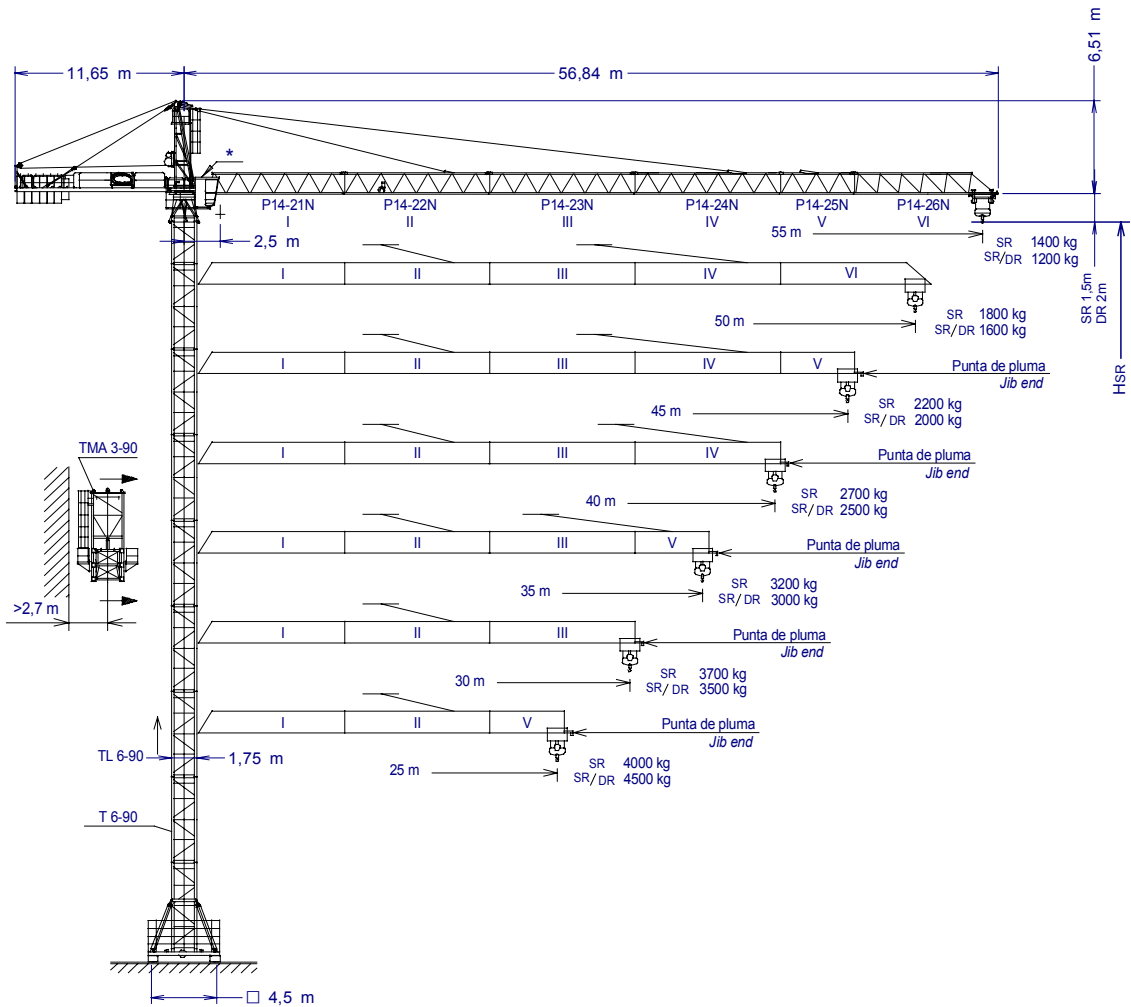

*Cabina opcional * Optional cabin	$H_{DR} = H_{SR} - 0,5$	TMA 3-90 ----- 158.35.000	BN 45-6-100 ----- 145.20.500
	$H_{SR} =$ Altura máxima bajo gancho sin arristrar (m) Maximum height under hook without fastening (m)	TL3-90 ----- 158.32.000	ABH 100 ----- 201.23.000
	Punta de pluma 158.46.000 para alcances: Jib end 158.46.000 for these working radius: 25 m, 30 m, 35 m, 40 m & 45 m	TL6-90 ----- 158.31.000	P14-21N ----- 158.40.000
		T3-90 ----- 133.32.000	P14-22N ----- 158.41.000
		T6-90 ----- 133.31.000	P14-23N ----- 158.42.000
		TI-6-90 ----- 133.30.000	P14-24N ----- 158.43.000
		BE 2-45 ----- 133.22.000	P14-25N ----- 158.44.000
			P14-26N ----- 158.45.000

(H_{SR}) TRASLACION / TRAVELLING

(H_{SR}) ESTACIONARIA / STATIONARY

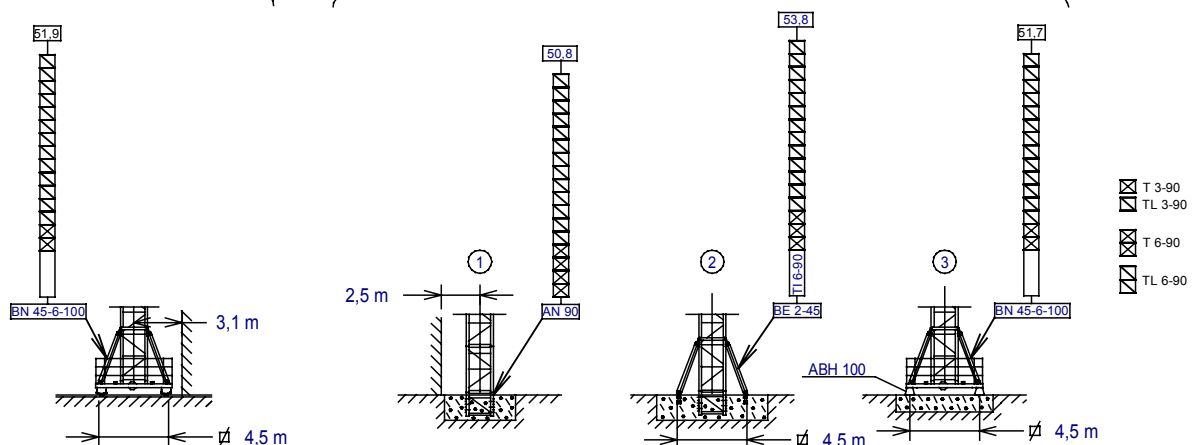

JASO EQUIPOS DE OBRAS Y CONSTRUCCIONES, S.L.









Fecha / Date: 05-07-06 - Reservado el derecho a modificaciones sin previo aviso / Subject to modification, without previous warning

 SR (kg)		Cargas máximas / Maximum loads SR1 - 3000 SR2 - 4000						3000-4000 kg...a	
		Alcance del gancho (m) / Hook reach (m)							
PLUMA JIB		55	50	45	40	35	30	25	
55 m		1400	1580	1800	2075	2430	2900	3000-3560	29,12-22,5 m
50 m		-----	1800	2045	2350	2745	3000-3265	3000-4000	32,35-25 m
45 m		-----	-----	2200	2525	2945	3000-3500	3000-4000	34,41-26,59 m
40 m		-----	-----	-----	2700	3000-3145	3000-3735	3000-4000	36,47-28,18 m
35 m		-----	-----	-----	-----	3000-3200	3000-3800	3000-4000	35-28,64 m
30 m		-----	-----	-----	-----	-----	3000-3700	3000-4000	30-27,95 m
25 m		-----	-----	-----	-----	-----	-----	3000-4000	25 m

 SR / DR (kg)		Cargas máximas / Maximum loads SR1/DR1 - 3000/6000								3000 /6000 kg...a	
		Alcance del gancho (m) / Hook reach (m)									
PLUMA JIB		55	50	45	40	35	30	25	20	15	
55 m		1200	1380	1600	1875	2230	2700	3000 /3360	3000 /4350	3000 /6000	27,5 /15 m
50 m		-----	1600	1845	2150	2540	3000 /3065	3000 /3800	3000 /4900	3000 /6000	30,56 /16,67 m
45 m		-----	-----	2000	2325	2745	3000 /3300	3000 /4080	3000 /5250	3000 /6000	32,5 /17,75 m
40 m		-----	-----	-----	2500	2945	3000 /3535	3000 /4360	3000 /5600	3000 /6000	34,44 /18,79 m
35 m		-----	-----	-----	-----	3000	3000 /3600	3000 /4440	3000 /5700	3000 /6000	35 /19,09 m
30 m		-----	-----	-----	-----	-----	3000 /3500	3000 /4320	3000 /5550	3000 /6000	30 /18,64 m
25 m		-----	-----	-----	-----	-----	-----	3000 /4500	3000 /5775	3000 /6000	25 /19,32 m

**CARACTERISTICAS DE MECANISMOS
MECHANISMS FEATURES**







Mecanismos sin VF: Para 480V Potencias y velocidades: 20% más
 Mechanisms without VF: For 60Hz Powers and speeds: 20% more

*opcional *optional								
	EC2556 SR1	* EC3380VF SR1	EC2544 SR2	* EC3360VF SR2	TG1125VF	OG1108VF	TC465VF	TH1210
 t m/min	1,5 3 3 56 28 7	1,5 3 0...80 0...40	2 4 4 44 22 5,5	2 4 0...60 0...30	0...25 m/min	0...0,2 0,2...0,4 0,4...0,8 r/min sl/min	0...15 15...32 32...65 m/min	1 m/min
 t m/min	3 6 6 28 14 4	3 6 0...40 0...20						
kW	18,4	24,2	18,4	24,2	2 x 4	2 x 4	3	9,2
Máx. recorrido gancho Maximum hook course	SR 136m 3 capas/ layers 240m 5 capas máx. / max. layers		SR 102m 3 capas/ layers 272m 7 capas máx./max. layers		 400V 50Hz	Potencia necesaria con ... Power required with ... EC 25XX=37,4 kW EC 33XXVF=43,2 kW *		

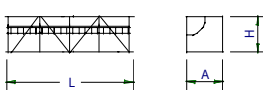
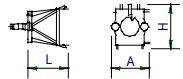
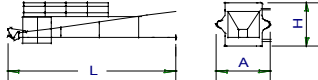
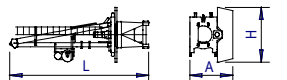
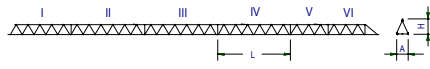
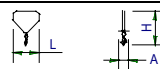
Importante: A medida que la altura bajo gancho aumenta, disminuye la capacidad de carga de la grúa. Para alturas superiores a la autoestable consultar a JASO EQUIPOS DE OBRAS Y CNES, S.L.

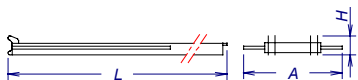
Important: When the height under hook increases, the hoisting load will decrease. If the height under hook is higher than the free standing height, consult to JASO EQUIPOS DE OBRAS Y CNES, S.L.

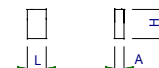

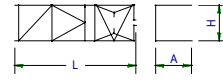
DENOMINACION / DENOMINATION		L (m)	A (m)	H (m)	P / W (kg)	
Torre Tower section	T16-90		6,236	2,095	2,095	2500
	TL6-90		6,136	1,818	1,818	1892
	TL3-90		3,186	1,818	1,818	960
	T6-90		6,235	1,818	1,818	2280
	T3-90		3,235	1,818	1,818	1212
Torre asiento de pista. Base punta de torre y orientación Slewing table, Tower head base and Slewing mechanism			3,390	2,060	2,150	3400
Punta de torre Tower head			6,164	1,200	1,350	1210
Conjunto asiento pista + punta torre + orientación + elevación Slewing table assembly + tower head + slewing mechanism + hoisting mechanism			9,554	1,920	2,440	4610
Tramo de pluma Jib section	P14-21N (I)		10,150	1,366	1,665	965
	P14-22N (II)		10,160	1,226	1,646	945
	P14-23N (III)		10,160	1,226	1,547	785
	P14-24N (IV)		10,160	1,226	1,547	655
	P14-25N (V)		5,267	1,226	1,665	345
	P14-26N (VI)		10,156	1,226	1,737	530
Polipasto Hook assembly	SR		0,76	0,160	0,960	190
	DR		1	0,235	1,288	293
Carro Crab	SR		1,100	1,330	0,730	195
	DR		1,410	1,471	1,204	295
Contrapluma con plataformas Counterjib with platforms			10,70	1,410	0,430	1575
Plataforma y cabina Platform and cabin			3,69	1,630	2,250	820
Contrapeso Counterweight	Grande / Big Pequeño / Small		1,080	0,500	2,025	2360
			1,080	0,500	1,305	1500
Lastre Ballast			3,800	0,580	1,500	6000
Torre de montaje Jacking cage			6,420	2,535	2,410	3080

LASTRES INFERIORES / LOWER BALLASTS

Para alturas intermedias tomar el lastre correspondiente a la altura superior
For intermediate heights take the ballast corresponding to the higher height

Altura bajo gancho (m) / Height under hook (m)	19,6	31,6	40,6	46,6	52,6
Número de piedras a colocar Number of ballast blocks to put	6	8	10	12	14



Torres Towers	Altura Height	Diagrama de la torre						Torres Towers	Altura Height
1	3,55	TL 3-90	TL 3-90	TL 3-90	TL 3-90	TL 3-90	158.32.000	1	3,55
2	6,50							2	6,50
3	9,45							3	9,45
4	12,40							4	12,40
5	15,35							5	15,35
6	18,30							6	18,30
7	21,25							7	21,25
8	24,20							8	24,20
9	27,15							9	27,15
10	30,10							10	30,10
11	33,05							11	33,05
12	36,0							12	36,0
13	38,95							13	38,95
14	41,90		T 3-90 TD 3-90	T 3-90 TD 3-90	T 3-90 TD 3-90	T 3-90 TD 3-90	T 3-90 133.32.000 TD 3-90 133.32.500	14	41,90
15	44,85	AN 90		TN 17/T 3-90	TN 17/T 3-90	TN 17/T 3-90	TN 17/T 3-90 139.36.000	15	44,85
16	47,80	AND 90		TN 17 TND 17	TN 17 TND 17	TN 17 TND 17	TN 17 141.31.000 TND 17 141.31.500	16	47,80
17	50,75			TR 17A TRD 17A	TR 17A TRD 17A	TR 17A TRD 17A	TR 17A 141.30.400 TRD 17A 141.30.800	17	53,11
				TR 17 TRD 17	TR 17 TRD 17	TR 17 TRD 17	TR 17 141.30.000 TRD 17 141.30.500	18	57,43
								19	61,75
								20	66,07
								21	70,39
								22	74,71
								23	79,03
								24	84,40
								25	88,72
								26	93,04

AN 90	133.21.000
AND 90	133.21.800
AN 17	141.21.000
AND 17/20/23	142.21.800
ANDC 17/20/23	142.21.700
AR 17	141.21.500
ARD 17/20/23	142.21.900
ARDC 17/20/23	142.21.600

AR 23	141.36.500
ARD 17/20/23	142.30.000
ARDC 17/20/23	142.30.500

Transporte grúa auto estable con traslación de 4,5x4,5m. y sin lastre

Free standing crane transport with travelling base of 4,5x4,5m. without base ballast

En camiones / In trucks

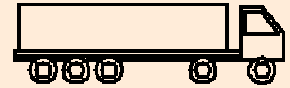

5 unidades / 5 units

En contenedores / In containers

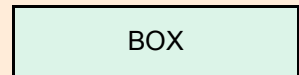

6 unidades / 6 units

Las configuraciones de torre representadas son recomendaciones de montaje que pueden ser utilizadas en cualquier instalación. Cada tramo de torre, en la posición indicada, puede asimismo ser utilizado como elemento inferior de torre en grúa autoestable estándar con su correspondiente altura bajo gancho. Configuraciones de torre para mayores alturas bajo gancho o con diferentes tramos de torre no representadas aquí, pueden ser también posibles aunque deben ser verificadas y confirmadas por escrito por nuestro departamento técnico en cada caso individual y antes de que empiece la instalación de la grúa.

The represented tower configurations are assembly recommendations that can be used in any installation. Each tower section in its indicated position can also be used as the lower element of the mast tower in standard freestanding crane with its corresponding height under hook. Tower configurations not shown here, with greater heights under hook or with different tower sections, are also possible but must be checked and confirmed in writing by our technical department in every individual case and before crane installation starts.

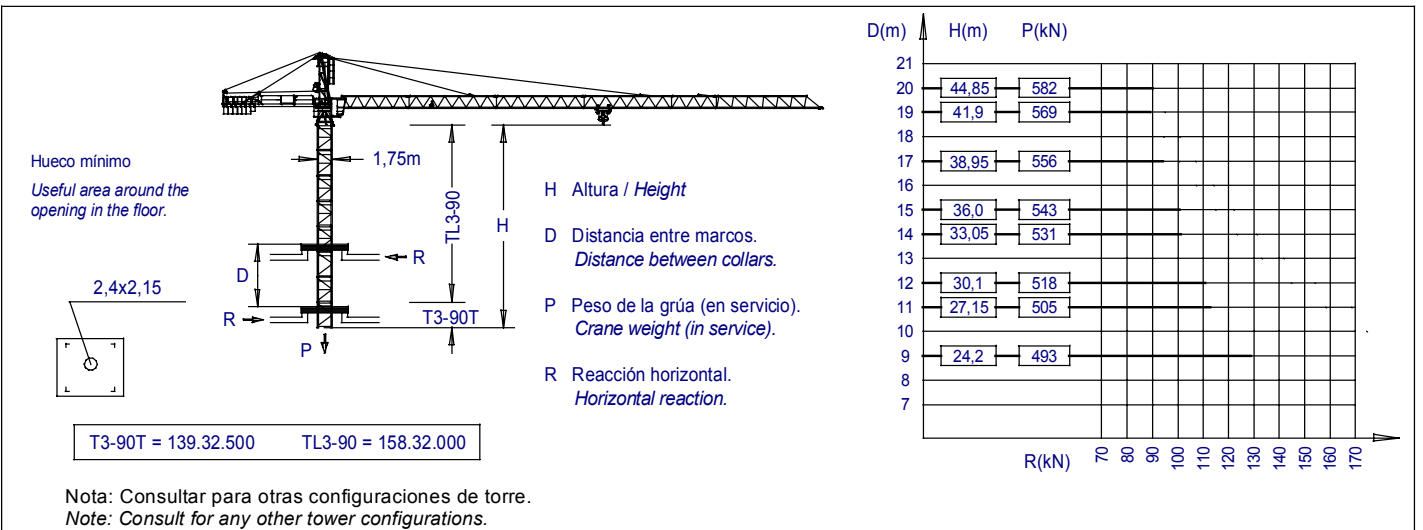

JASO EQUIPOS DE OBRAS Y CONSTRUCCIONES, S.L.

Ctra./Rd. Madrid - Irún Km. 415
 20.213 IDIAZABAL (Gipuzkoa)
 ESPAÑA / SPAIN
 P.O. Box, 23 - 20.200 BEASAIN

Tel. +34 943 - 18 70 00
 Fax. +34 943 - 18 70 20
 E-mail: jaso@jaso.com
 http://www.jaso.com

Fecha / Date: **05-07-06**

Reservado el derecho a modificaciones sin previo aviso / Subject to modification, without previous warning

DELEGACION / DELEGATION