

# ZOOMLION ROUGH TERRAIN CRANE ZRT1100



**ZOOMLION**

**40**  
PRODUCTS

**CE** **ANSI** **EAC**

# CONTENTS

HIGHLIGHTS .....	2
DEMENSIONS .....	3
WEIGHTS .....	3
LIFTING HEIGHT CURVE/LIFTING CAPACITY TABLES .....	4-9
TECHNICAL DESCRIPTION .....	10-13
TECHNICAL PARAMETER .....	14

# HIGHLIGHTS

## Powerful performances

- The 49m main boom of super large U-shape cross section achieves stronger rated lifting capacity reaching 110t and better bearing capability; its comprehensive lifting capacity surpasses other competing products of the same tonnage level in the industry, thanks to its super-strong outriggers + lift-and-carry capability.
- Golden configuration of the power train: Cummins (US) engine + DANA (US) transmission + KESSLER (Germany) axles, four-wheel drive, four-wheel multi-mode steering, altogether achieves higher maximum driving speed and gradeability.

## Superior reliability and durability

- Key parts and components adopt renowned brands at home or abroad. The crane has passed reliability tests conducted in regions such as plateaus, deserts, mountains and hills, etc., as well as tests done by Chinese and international institutes with issued ANSI and CE certificates.

## High intelligence and safety

- The crane is configured with an intelligent device management platform which provides functions such as monitoring and control of crane operations and driving safety, fault diagnosis, and operational information recording, etc., and provides real-time reminding to the operator on safety, malfunction and maintenance.

## Great comfort and beautiful contour

- Zoomlion's new generation of driver's cab is equipped with a push front window and a panoramic sunroof, providing better field of vision for the operator. The cab can be tilted backward, thus reducing operational fatigue. The 12-inch large display and spatial arrangements of instruments in an ergonomic way enhance the operator's operational comfort.
- The green and environment-friendly painting provides the crane with a fashion look and strong visual enjoyment from its expression of both beauty and strength.



# DEMENSIONS

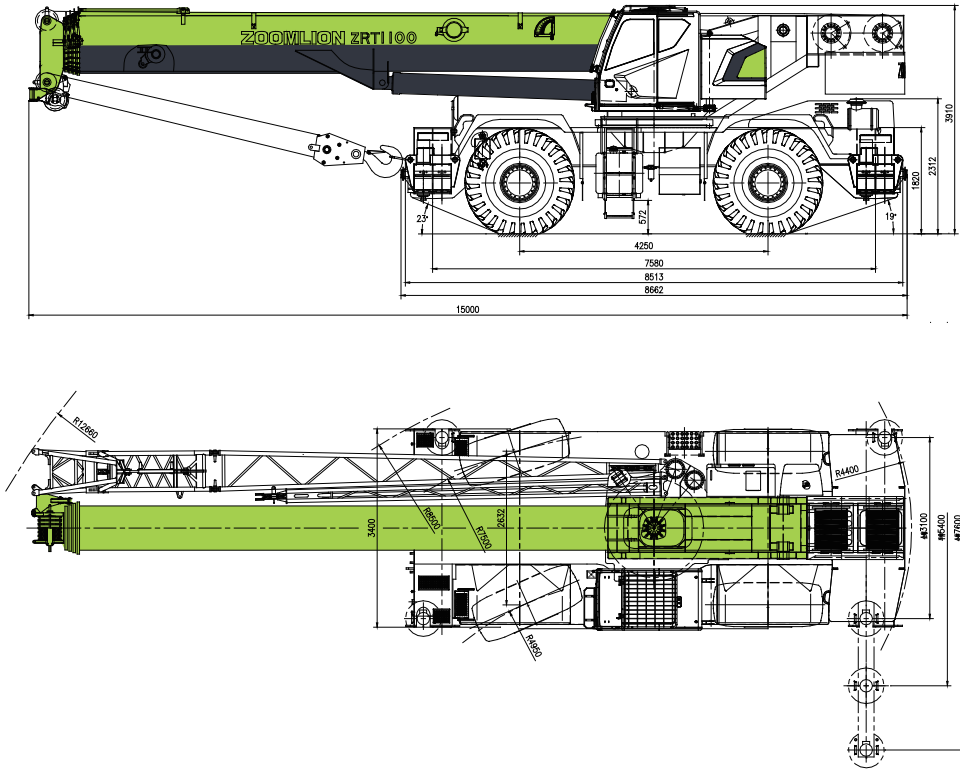

# WEIGHTS

## Hook block and hook ball

Rated load/t	Number of sheave	Reeving	Hook block weight/kg	Standard/Optional
85T	6	13	620	standard
6.5T	-	1	150	standard
110T	7	14	840	optional
35T	3	6	380	optional

## Axle load

Shaft	Front axle	Rear axle	Total weight
Axle load/t	29T	31T	60T
Note	With main and auxiliary hooks		

## Working speeds

	km/h min. MIN.	km/h max. MAX.	%	
29.5-25-34PR	0-1.6	35	96.7	6/R6

	Operation Speed	Rope diameter/length	Max. single line pull
①	130m/min	Φ 20mm/260m	6500Kg
②	130m/min	Φ 20mm/140m	6500Kg
360	1.6r/min		
▲	Min.boom derricking up time 60s Min. boom derricking down time 90s		
▲	Telescoping out/in time 135s		

# LIFTING HEIGHT CURVE

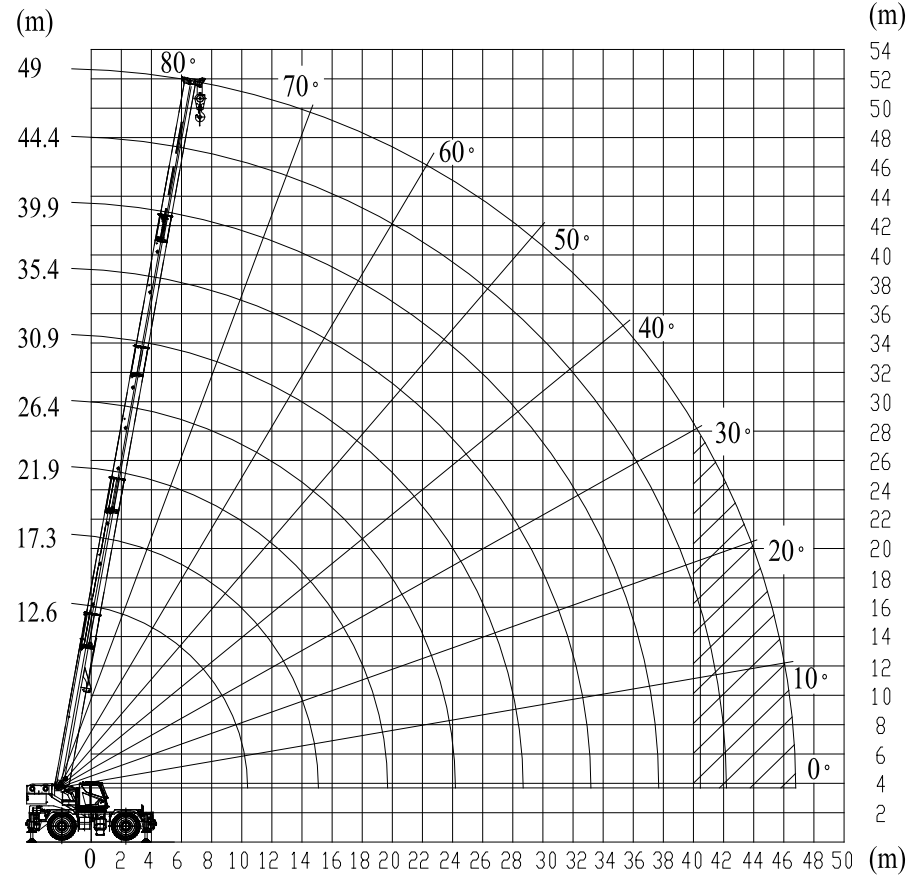

# LIFTING CAPACITY TABLES

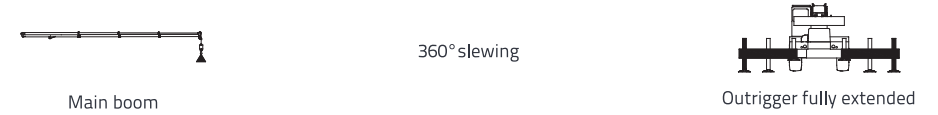

Working radius (m)	cylinder I fully extended, outrigger fully extended, 12.5t counterweight								
	12.6	17.3	21.9	26.4	30.9	35.4	39.9	44.4	49
2.5	110000**								
3	100000**	66000							
3.5	85000*	66000	47000						
4	78000	66000	47000	38000					
4.5	72000	63000	47000	38000					
5	68000	58000	46000	38000	34000				
5.5	62500	53500	43500	38000	34000				
6	57500	49500	41000	37000	33000	30000			
7	48000	43000	38000	35200	30000	27500	21000		
8	38500	36500	34000	32000	27000	25500	21000		
9	29000	27000	28500	28500	25000	24000	20000	17500	
10		22500	22800	24600	22500	22500	19000	17000	13000
11		19500	18600	20200	18600	21200	18000	15800	13000
12		16000	15500	17800	16400	19000	16500	14600	12800
14			10800	12800	12500	13500	13800	13000	11800
16			8500	9800	9800	10000	11000	11000	10500
18				7500	7800	8600	9000	9600	9600
20				5800	6400	7000	7300	7800	8000
22					4800	5800	6200	6200	6700
24					4000	4700	4900	5200	5500
26						3700	4000	4400	4800
28						3000	3300	3700	3800
30							2600	3000	3200
32							2100	2500	2700
34								2100	2300
36								1700	1850
38									1500
40									1200
42									1000
I (m)	0	4.7	9.3	9.3	9.3	9.3	9.3	9.3	9.3
II (m)	0	0	0	4.5	9	13.5	18	22.5	27.1
Reeving	12	12	8	8	6	6	4	4	4
Hook									85t

# LIFTING CAPACITY TABLES



Main boom

360° slewing

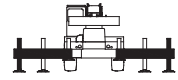

Outrigger fully extended



Main boom

360° slewing

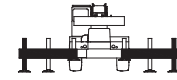

Outrigger fully extended

Working radius (m)	cylinder I extended to 50%, outrigger fully extended, 12.5t counterweight								
	12,6	17,3	21,8	26,3	30,8	35,3	39,9	39,8	44,4
2.5	110000**								
3	100000**	66000							
3.5	85000*	66000	38000						
4	78000	66000	38000	34000					
4.5	72000	63000	38000	34000					
5	68000	58000	38000	34000	30000				
5.5	62500	53500	37000	34000	30000				
6	57500	49500	36000	32000	30000	24000			
7	48000	43000	34000	31000	29000	23000	21000		
8	38500	36500	32000	30500	27000	22000	21000	18000	
9	29000	27000	28000	29000	26000	20000	20000	18000	13500
10		22500	24500	25500	24500	18400	19000	16400	13500
11		19500	20500	21500	22500	16800	18000	15000	13000
12		16000	17500	18200	18800	15500	16500	14000	12600
14			12400	12800	13500	13400	13800	12100	10800
16			9500	10400	11000	11800	11000	10600	9500
18				8400	8500	8800	9000	9500	8500
20				6500	7000	7400	7300	7500	7700
22					5800	6000	6200	6000	7000
24					4800	5000	4900	5000	5800
26						4200	4000	4000	4800
28						3200	3300	3200	4000
30							2600	2800	3200
32							2100	2500	2600
34									2400
36									1800
38									1200
40									
42									
I (m)	0	4,7	4,7	4,7	4,7	4,7	9,3	4,7	4,7
II (m)	0	0	4,5	9	13,5	18	18	22,5	27,1
Reeving	12	12	8	8	6	6	4	4	4
Hook	85t								

Working radius (m)	cylinder extended to 0%, outrigger fully extended, 12.5t counterweight						
	12,6	17,1	21,6	26,1	30,6	35,1	39,7
2.5	110000**						
3	100000**	38000					
3.5	85000*	38000	34000				
4	78000	38000	34000	30000			
4.5	72000	38000	34000	30000			
5	68000	38000	34000	30000	25000		
5.5	62500	37000	34000	29000	25000		
6	57500	36000	32000	28000	24000	19000	
7	48000	34000	31000	26000	22500	19000	
8	38500	32000	29000	24500	21000	18000	15000
9	29000	30000	27000	23000	18800	17000	15000
10		26000	25500	22000	17000	15400	13800
11		22000	22000	20500	15800	14100	12800
12		18400	18800	20000	14500	13000	11800
14			14200	15000	12800	11200	10200
16			11000	11500	11200	9800	9000
18				9500	10000	8800	8000
20				8000	8300	8000	7200
22					7000	7300	6600
24					5800	6200	6100
26						5000	5700
28						4200	4500
30							4000
32							3500
I (m)	0	0	0	0	0	0	0
II (m)	0	4,5	9	13,5	18	22,5	27,1
Reeving	12	10	8	8	6	6	4
Hook	85t						

# LIFTING HEIGHT CURVE

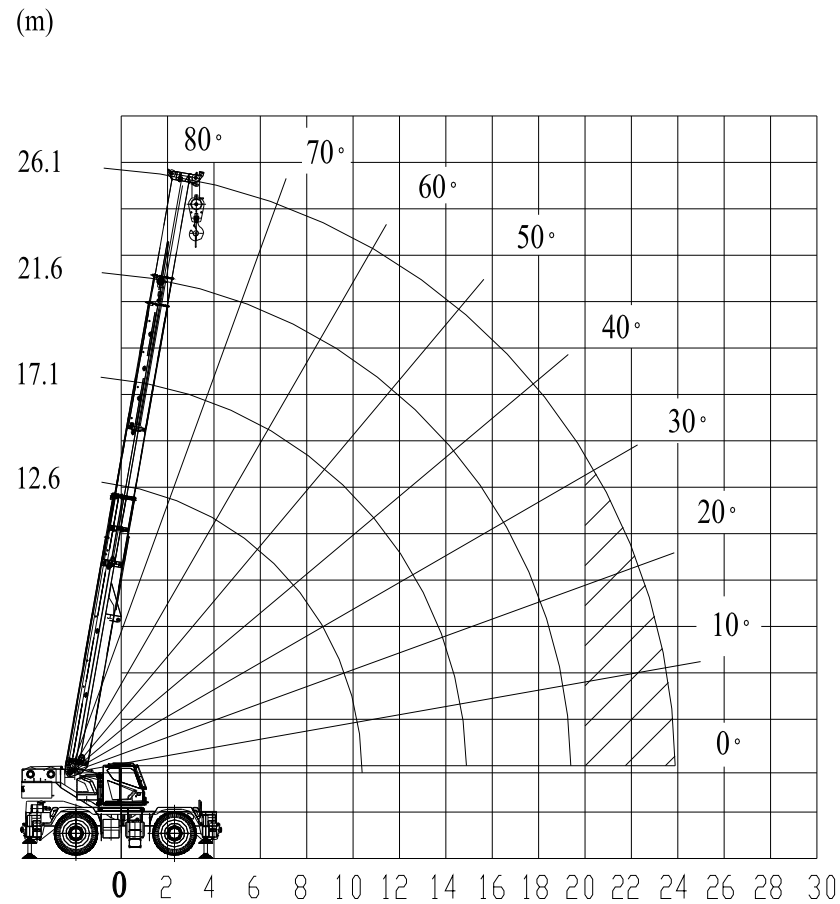

# LIFTING CAPACITY TABLES

(m)



32  
30  
28  
26  
24  
22  
20  
18  
16  
14  
12  
10  
8  
6  
4  
2  
(m)

Working radius (m)	cylinder I extended to 0%, tire stationary condition, 360° operation, 12.5t counterweight			
	12.6	17.1	21.6	26.1
3	21000	20000		
3.5	18000	17500		
4	16000	15200	16500	14200
4.5	13800	13000	14000	12000
5	11000	11000	11500	10200
5.5	9800	9500	9800	9200
6	8500	8000	8800	8300
7	6200	6200	7000	7200
8	4500	4800	5400	6000
9	3200	3400	4000	4500
10		2800	3200	3600
11		2200	2500	3000
12		1800	2000	2600
14			1700	2000
16			1300	1600
18				1200
20				1000
22				
I(m)	0	0	0	0
II(m)	0	4.5	9	13.5
Reeving	12	10	8	8
Hook	85t			

# LIFTING CAPACITY TABLES



(UNIT: KG)

Working radius (m)	cylinder I extended to 0%, Tire stationary condition, front operation 12.5t counterweight			
	12.6	17.1	21.6	26.1
3	30000	28000		
3.5	27000	26000		
4	24000	23500	23000	22000
4.5	21000	21000	21000	20000
5	20000	19500	19000	18000
5.5	17000	17800	16500	16000
6	15000	16000	15000	14500
7	11500	13500	12500	12500
8	8800	10500	10000	9800
9	6200	8800	8500	8400
10		7200	7400	7200
11		5800	6000	6200
12		4500	4800	5000
14			3600	3800
16			2800	3000
18				2200
20				1600
22				
I (m)	0	0	0	0
II (m)	0	4.5	9	13.5
Reeving	12	10	8	8
Hook	85t			

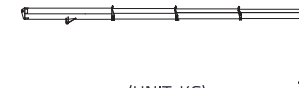

(UNIT: KG)

Working radius (m)	cylinder I extended to 0%, driving condition, front operation, 12.5t counterweigh			
	12.6	17.1	21.6	26.1
3	19500	19000		
3.5	17000	16800		
4	15500	15200	15000	14500
4.5	13500	13500	13500	13000
5	12000	12000	12200	11500
5.5	10800	10500	11000	10000
6	9800	9600	9800	8800
7	8000	8500	8400	7500
8	6600	7200	7200	6500
9	4500	5000	6500	5500
10		4400	5400	4600
11		3600	4300	3600
12		2800	3200	2800
14			2200	2200
16			1600	1700
18				1400
20				1000
22				
I (m)	0	0	0	0
II (m)	0	4.5	9	13.5
Reeving	12	10	9	8
Hook	85t			

# LIFTING HEIGHT CURVE

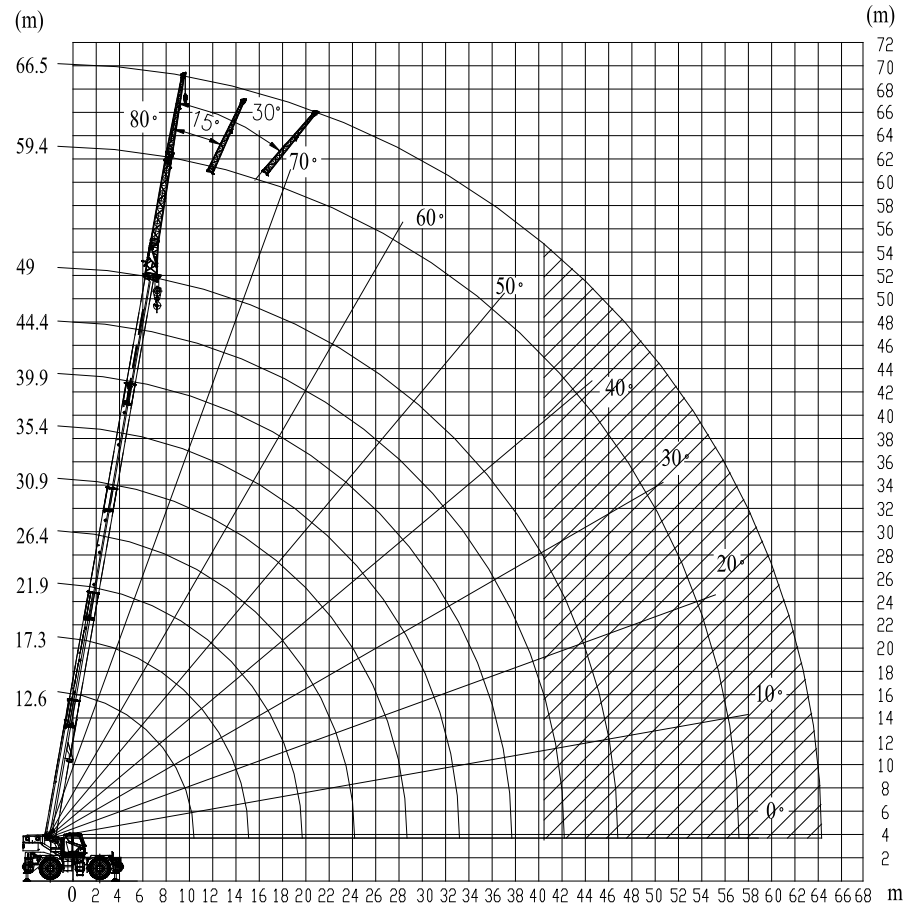

# LIFTING CAPACITY TABLES



360° slewing



Working radius (m)	outrigger fully extended, 12.5t counterweight					
	0°		15°		30°	
	Radius(m)	Lifting capacity	Radius (m)	Lifting capacity	Radius (m)	Lifting capacity
80	12.6	6500	14.8	4600	16.4	4300
78	14.9	6300	16.9	4400	18.5	4200
76	17.1	6000	19	4300	20.5	3800
74	19.2	5600	21	4100	22.5	3600
72	21.3	5200	23	4000	24.5	3500
70	23.3	5000	25	3900	26.4	3400
68	25.3	4600	26.9	3800	28.2	3300
66	27.2	4500	28.8	3500	30	3300
64	28.8	4000	30.6	3200	31.8	3000
62	30.4	3200	32.2	2800	33.5	2600
60	31.9	2700	33.7	2500	35	2400
58	33.5	2400	35.2	2200	36.4	2100
56	35	2200	36.7	2000	37.8	1800
54	36.5	1900	38.1	1600	39.1	1500
52	37.9	1600	39.5	1400	40.4	1300
50	39.3	1400	40.8	1200	41.7	1100
48	40.7	1200	42.1	1100	43	1000
46	42.1	1100	43.4	1000	44.2	900
44	43.4	1000	44.6	900		
42	44.6	900	45.8			
Reeving	1					
Hook	6.5t					

# LIFTING CAPACITY TABLES



Main boom + jib 17,5m

360° slewing

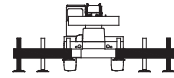

Outrigger fully extended

Working radius (m)	outrigger fully extended, 12.5t counterweight					
	0°		15°		30°	
	Radius (m)	Lifting capacity	Radius (m)	Lifting capacity	Radius (m)	Lifting capacity
80	14.3	4000	17.8	2200	21	1800
78	16.7	3700	20.1	2000	23.2	1600
76	19.1	3300	22.5	1900	25.4	1500
74	21.5	3000	24.8	1800	27.6	1500
72	23.7	2900	27	1800	29.7	1500
70	25.9	2800	29.2	1800	31.8	1400
68	28.1	2700	31.3	1700	33.8	1400
66	30.2	2700	33.3	1700	35.8	1350
64	32.3	2600	35.3	1700	37.6	1350
62	34.4	2400	37.3	1600	39.4	1300
60	36.3	2200	39.2	1600	41.2	1300
58	38.3	1800	41	1600	42.9	1300
56	40.1	1500	42.8	1400	44.5	1300
54	41.6	1400	44.4	1300	46.1	1200
52	43.2	1200	45.9	1100	47.5	1100
50	44.7	1100	47.3	1000	48.8	1000
48	46.2	1000	48.7	900	50	900
Reeving	1					
Hook	6.5t					

# NOTES

a)The operating modes marked with \* in Table are ones which need using a removable pulley block and selecting a reeving factor of 13 when the crane is working in a full-range working area. For ones marked with \*\*, a reeving factor of 14 should be selected, and a 110 t hook should be used with an additional special device.

b)Crane load ratings are based on the crane being leveled and standing on a firm and uniform supporting surface.

c)Crane load ratings on outriggers are based on all outrigger beams being positioned according to the applicable lift chart and the tires raised free of the supporting surface.

d)CRANE LOAD RATINGS MUST NOT BE EXCEEDED. DO NOT ATTEMPT TO TIP THE CRANE TO DETERMINE ALLOWABLE LOADS.

e)Lift the load vertically. Do not pull the load at an angle.

f)When either radius or boom length, or both, are between listed values, the smaller of the two listed load ratings shall be used.

g)Do not operate at longer radii than those listed on the applicable lift chart (cross hatched areas shown on range diagrams) as tipping can occur without a load on the hook.

h)The boom angles shown on the lift charts give an approximation of the operating radius for a specified boom length. The boom angle, before loading, should be greater to account for boom deflection.

i)Rated loads include the weight of hook block, slings, and auxiliary lifting devices. Their weights shall be subtracted from the listed rated load to obtain the net load that can be lifted.

j)Consult appropriate section of the Operator's Manual for more exact description of hoist line reeving.

k)The use of more parts of line than required by the load may result in having insufficient rope to allow the hook block to reach the ground. Choose the correct line parts to get a rope in the proper length.

l)Properly maintained wire rope is essential for safe crane operation. Consult the Operator's Manual and Maintenance Manual for proper maintenance and inspection requirements.

m)When the rotation-resistant wire rope is used, the allowable rope loading shall be the breaking strength divided by five (5), unless otherwise specified by the wire rope manufacturer.

n)The user shall operate at reduced ratings to allow for adverse job conditions, such as: soft or uneven ground, out of level conditions, high winds, side loads, pendulum action, jerking or sudden stopping off loads, hazardous conditions, experience of personnel, two-machine lifts, traveling with loads, electric wires, etc. (side pull on boom or jib is hazardous). If the wind speed is higher than the maximum permissible value (45 ft/s (13.8 m/s), grade 6) or it is fulminous during crane operation, stop the work, fully retract the boom and correctly stow the boom.

o)Load ratings are dependent upon the crane being maintained according to the Operator's Manual and Maintenance Manual.

# TECHNICAL DESCRIPTION



## Engine

Engine type ..... CUMMINS QSB6.7  
Rated power ..... 194 KW / 2400 RPM  
Oil tank capacity ..... 300L  
Exhaust emissions: Non-road Emission Standard III



## MAIN BOOM

The box-shaped main boom consists of 5 U-type boom sections made of high-strength steel.  
The main boom head is equipped with 6 sheaves, which is convenient for changing reeving factors without removing the wedges. The rooster sheave and a dismountable pulley block are included in the standard configuration.  
Min. main boom length (with telescopic sections completely retracted): 12600 mm  
Max. main boom length (with telescopic sections completely extended): 49000 mm  
Min. telescoping out time ..... 135 s  
Derrick angle and speed ..... - 1° - 80° / 60 s



## MAX. BOOM LENGTH WITH JIB EXTENSION

It consists of two jib sections of lattice structure. The jib section II is secured into the jib section I, and can be extended outward from one side of the section I. The whole jib is side stowed with the main boom via moveable pins during driving.  
A sheave is assembled at the jib head.  
Offset ..... 0°, 15° and 30°  
Jib length ..... 10.4m – 17.5 m



## MAIN AND AUXILIARY WINCHES

The main and auxiliary winches are equipped with the same spare parts. An axial variable-displacement hydraulic motor drives the drum to rotate through a planetary reducer, so as to lift and lower a load.  
Max. hoist rope strength ..... 6500 kg  
Max. hoist rope speed ..... 130 m/min (At the 4<sup>th</sup> layer)  
Rope diameter ..... Φ20 mm  
Main winch rope length ..... 260 m  
Auxiliary winch rope length ..... 140 m

# TECHNICAL DESCRIPTION



## MAIN AND AUXILIARY WINCHES

Rotatable main hook: 85 t, with 6 sheaves and hook latch, secured at the chassis frame in front of the slewing table.

Rotatable auxiliary hook: 6.5 ton, with hook latch, used with the rooster sheave and jib, secured at the auxiliary hook holder on the chassis frame.

Rotatable hook: 110 t (optional), with 7 sheaves and a hook latch, secured at the chassis frame in front of the slewing table.



## SWING

It consists of a hydraulic motor, two planetary gear reducers, a pinion gear and a swing bearing, etc. Via the planetary gear reducer, the hydraulic motor drives the pinion gear to rotate and makes the swing bearing outer ring rotate around its inner toothed ring fixed on chassis frame, providing superstructure with 360° unlimited swing.

Hydraulically controlled usually-closed brake, capable of free swing function, and installed with a pneumatic swing lockout device.

Swing speed ..... 0 – 1.6 r/min



## HYDRAULIC SYSTEM

The dual variable plunger pumps supply oil to the telescoping, derricking and hoist mechanisms.

A gear pump supplies oil to the slewing and steering mechanisms.

Another gear pump mounted on the engine supplies oil to the outriggers, braking system, oil radiator of the torque converter and air conditioner.

Hydraulic oil tank capacity ..... 1100 L



## OPERATOR CAB

The cab is side-mounted and adopts left-hand drive. A single seat is installed inside the cab.

A hydraulic steering gear (manufacturer: EATON Ji'ning) and an air conditioner for both heating and cooling (manufacturer: Yuxin He'nan) are installed in the crane.

Emission complies with the requirements of Europe environment protection standards.

There are two control boxes on the both sides of operator's seat. The left / right control box can be pulled up. The controls of the superstructure are arranged according to the requirements of ASME B30.5-2007 standard and comply with ISO (International Organization for Standardization) standard.

Length ..... 1810 ± 5 mm

Width ..... 1050 ± 5 mm

Height ..... 1710 ± 5 mm

# TECHNICAL DESCRIPTION



## OUTRIGGER SYSTEM

4 H-type outriggers, hydraulically controlled, can be operated in the cab simultaneously or independently.

Each vertical jack cylinder is equipped with a two-way hydraulic lock to ensure that outriggers are secured reliably during working or driving.

Outrigger boxes are directly welded onto the chassis frame.

The outriggers can be completely extended, intermediately extended or completely retracted for different crane operations.

Outrigger spread (Height): 7580 mm

Outrigger spread (Width): 7600 mm (fully extended)

5400 mm (half extended)

3100 mm (fully retracted)



## AXLES

Front axle :A rigidly connected steering and driving axle, installed with a planetary reducer and a brake.

Rear axle:A full-floating steering and driving axle, installed with a planetary reducer and a brake.



## STEERING

Fully-hydraulic power steering gear □The cylinder of steering and driving axle is controlled by the steering wheel to realize crane steering.

4 steering modes:

2-wheel steering – front wheel steering

2-wheel steering – rear wheel steering

4-wheel steering – all-wheel steering

4-wheel steering – crab steering



## BRAKES

Service brake Hydraulically controlled disc brake on 4 wheels

Parking brake Hydraulically released parking brake, under the action of the spring mounted on the input shaft of front axle.

# TECHNICAL DESCRIPTION



## ELECTRIC SYSTEM

24 Volt DC

2 batteries with 12 V rated voltage and 120 Ah rated current



## SUSPENSION SYSTEM

Front axle: rigidly mounted to the chassis frame

Rear axle: oscillation axle, connecting to chassis frame via a hydraulic suspension cylinder



## SAFETY DEVICE

Rated capacity indicator (RCI)	Hydraulic safety valve
Rotating beacon and horn	Swing brake
Hoisting limit switch	Swing lockout device
Lower limit switch	Boom angle indicator
Balance valve	Outrigger beam retaining pin
Hydraulic lock	Emergency stop button



## COUNTERWEIGHT

Counterweight :12500kg(27500lbs)

Length..... 3200mm

width..... 1300mm

Height..... 785mm

# TECHNICAL PARAMETERS

Type	Item	Value	
Working performance	Max. rated lifting capacity × working radius	kg.m	110000×2.5
	Max. load moment of main boom	kN.m	3381
	Max. lifting height of main boom (fully extended)	m	49.2 (from the lower end of hook to ground, i.e. from 2.5 m below the boom top point to the ground)
	Max. lifting height of jib	m	66.8 (from the lower end of hook to ground, i.e. from 2.3 m below the boom top point to the ground)
Dimensions	Overall dimensions (L × W × H)	mm	15000×3400×3910
	Outrigger spread(Height × Width)	mm	7580×7600
	Main boom length	mm	12600 - 49000
	Jib length	mm	10400 - 17500
	Boom angle	°	-1 - 80
	Swing range		360° unlimited swing (Full range)
Working speeds	Max. hoist rope speed (Main winch)	m/min	130
	Min. boom telescoping out time	s	135
	Min. boom telescoping in time	s	135
	Min. boom derricking up time	s	60
	Min. boom derricking down time	s	≤90
	Swing speed	r/min	0-1.6
Hydraulic system	Hydraulic oil tank capacity	L	1100
Gross vehicle mass	Gross weight	kg	60000
	Front weight	kg	29000
	Rear weight	kg	31000
Driving	Highest driving speed (forward/backward)	km/h	35/35
	Wheelbase	mm	4250
	Treads(Front / Rear)	mm	2632
	Max. gradeability	%	96.7

**ZOOMLION**

**Zoomlion Heavy Industry Science & Technology Co.,Ltd.**

**Add: No.677, Lugu Road, Zoomlion Industrial Park, Changsha, Hunan, China, 410205**

Copyright©2021 Zoomlion. All rights reserved. Reproduction and copying of any part of contents is not allowed for any purposes without Zoomlion's approval.

