



徐工徐工 助您成功
XCMG FOR YOUR SUCCESS

XGC15000A

CRAWLER CRANE



地址(Add): 中国江苏省徐州市金山桥经济开发区桃山路19号 邮编(Postal Code): 221004
No.19 Taoshan Road, Economic development zone of jinshanqiao,Xuzhou,Jiangsu Province,China
统一服务热线(Unified service hotline): 86 400-110-9999

销售热线Sales Hotline

销售电话(Sale Tel): 86 0516-87892094

销售传真(Sale Fax): 86 0516-87892074

电子邮件(E-mail): jjyxd@xcmg.com

服务质量投诉电话
(Quality Supervision Tel): 86 0516-87892587

服务热线Service Hotline

服务电话(Service Tel): 86 400-001-5678

服务传真(Service Fax): 86 0516-87892080

备件电话(Service Tel): 86 0516-87892086

备件传真(Service Fax): 86 0516-87892083



欢迎访问徐工商城
省心更省钱一站式



欢迎关注徐工海外经销商的微信
1. 微信名称: "XCMG(中国) 徐工徐工"
2. 微信公众账号: "徐工徐工海外直联"
3. 直接扫描上方二维码

—2022年1月版—

注: 出于产品不断改进的需要, 我们保留对产品型号、参数、配置进行变更的权力, 恕不另行通知。



CONTENTS

目录

P02

- Parts and System Description
- Safety Protection Devices
- Main Technical Parameters

P08

- HB-Standard heavy boom
- LB-Standard light boom
- HJ-Standard wind power jib
- SHB-Superlift heavy boom
- SHW Superlift tower jib-single boom(3.75m in width)
- SHJ-S Superlift wind power jib-single boom (3.75m in width)

P49

- Transport Plan

02

XGC15000A CRAWLER CRANE

P03-04 Parts and System Description

P05 Safety Protection Devices

P06-07 Main Technical Parameters

Parts and System Description

Boom system

The boom sections of XGC15000A crawler crane use high-strength seamless pipe as the chords and lacing tubes, supplemented by four-chord lattice structure which is welded by high strength steel plate, with equal section in the middle and variable section at two ends.

No.	Name	Length (m)	Qty.
1	Boom butt	10.5	1
2	12m boom transition section (heavy duty)	12	1
3	12m boom insert A (heavy duty)	12	2
4	12m boom insert B (heavy duty)	12	2
5	12m boom insert (heavy-duty, center hitch)	12	1
6	12m boom insert C (heavy duty)	12	2
7	10m boom transition section	10	1
8	3m boom insert	3	1
9	6m boom insert	6	1
10	12m boom top	12	1
11	12m boom insert A	12	1
12	12m boom transition section	12	1
13	7.5m wind power boom top	7.5	1
14	12m boom insert B	12	1
15	Heavy-duty boom head (with pulley block)	1.5	1
16	Light-duty boomhead (with pulley block)	1.5	1
17	3m boom transition section A (twin boom)	3	1
18	12m boom insert A (twin boom)	12	2
	12m boom insert B (twin boom)	12	2
19	12m boom insert C (twin boom)	12	1
	12m boom insert D (twin boom)	12	1
20	12m boom insert E (twin boom)	12	1
	12m boom insert F (twin boom)	12	1
21	3m boom transition section B (twin boom)	3	1
22	12m insert section (rear pendant)	12	1
W1	3m boom transition section A (strengthened type)	3	1
W2	12m boominsert A (strengthened type)	12	2
W3	12mboom insert B (strengthened type)	12	1
W4	12mboom insert C (strengthened type)	12	2
W5	12m boom insert (strengthened type, center hitch)	12	1
W6	3m boom transition section B (strengthened type)	3	1
W7	12m boom insert F (strengthened type)	12	2
W8	12m boominsert G (strengthened type)	12	1
W9	12m boom insert (heavy-duty, center hitch)	12	1
W10	12m boominsert D (strengthened type)	12	1
W10	12m boominsert D (strengthened type, for 114+12)	12	1
W11	12m boom transition section A (for 114+12)	12	1
W12	12m boom transition section B (for 114+12)	12	1

Boom luffing components

It adopts high-strength pendant structure and made of two groups of pendants. The pendant is formed by cutting high strength steel once, with high safety factor.

Mast

Standard mast is box-type structure, superlift mast is lattice structure, with good overall stability. Mast is equipped with raising device, superlift mast is equipped with automatic backstop system. Superlift mast can be used to assembled boom section in suspension state.

Turntable

Turntable is a box structure made of high-strength steel plate, connected with "I" type and box type beam in the middle of it, and arranged with reinforced plate near the slewing center.

Mechanism composition

See the following table for the configuration and use of the mechanisms of the crane.

No.	Mechanism name	Use	Position
1	Main hoist winch	Boom, jib, tower jib lifting operation	Near the slewing center of turntable
2	Aux. hoist winch	Boom, fixed jib and tower jib lifting operation	Behind main hoist winch
3	Boom luffing winch	Boom luffing operation	Middle and rear part of turntable
4	Superlift luffing winch	Superlift boom luffing operation	Superlift mast
5	Slewing gear	Superstructure slewing	In front of turntable
6	Travel gear	Crane travel	Drive sprocket of crawler track
7	Reeving winch (optional)	Wire rope reeving assistance	In front of turntable
8	Single top hoist winch	Auxiliary hook lifting and lowering	Boom butt

Hoist winch

Main and aux. winches have the same model and driven independently. They can work synchronously for heavy load lifting. Hoist winches adopt constant-closed disc brake, built-in reducer and variable displacement motor. The two winches use box bracket, pin shaft is used to connect them to turntable. All wire ropes used are rotation resistance. For main hoist winch, rope diameter is $\phi 28$ mm; For auxiliary hoist winch, rope diameter is $\phi 28$ mm.

Luffing winch

Boom luffing winch is twin drum form, with ratchet locking device, built-in speed reducer and constant-closed disc brake, rope diameter $\phi 28$ mm. Superlift luffing winch has ratchet locking device, built-in speed reducer and constant-closed disc brake, rope diameter $\phi 28$ mm.

Slewing gear

Slewing gear is arranged in front of turntable, with two planetary reducers. It is externally meshed with slewing bearing and has hydraulic buffering and free swing function. Constant-closed disc brake is used, reliable in work and easy for maintenance.

Slewing bearing

Three-row roller type slewing bearing is externally meshed, with features of high strength, head load bearing capacity and easy repair and maintenance. The upper and lower parts of the crane are separated by slewing bearing and connected by pin shaft, so as to reduce the transport weight of the basic machine.

Oil cylinder assembly

The connection of boom and turntable and the connection of car-body and track frame are all realized by the use of power pin. This crane is equipped with mast raising cylinder and outrigger cylinder. The operator's cab is also set with tilting cylinder and rotation cylinder.

Operator's cab

The operator's cab is ergonomically designed, safe and comfortable, with safety glass and guardrails. The cab is equipped with sunshades, sliding door, adjustable seat and air conditioning device for heating and cooling. When the crane is in transport, the cab can be turned 90° to the front of turntable (boom butt removed) to reduce the transport width. When the crane is in operation, the operator's cabin can be tilted upward 20° for high level vision.

Car-body

Car-body is made of high strength steel plate and welded in box type structure. Cross panel is set in the middle to strengthen its torsion stiffness, simple structure, high load bearing capacity and good rigidity.

Crawler travel device

Crawler travel unit consists of track frame, drive sprocket, idler roller, carrier roller, track roller and track shoes. Track frame is box-type structure, its connection part with car-body is partially strengthened, with cross panel installed in the middle of it.

Hydraulic system

It adopts electric proportional pilot variable pump control system, with combination of open and closed circuit, the system has good stability and fine speed regulation. Main/auxiliary hoist winches, travel unit and boom/jib luffing winch are all open pump control systems. Slewing gear is closed type pump control system, no need of balance valve and change valve, the transmission is stable without impact. Variable displacement motor drive is used for main/auxiliary hoist winch and travel unit with large range of speed regulation. The combination of variable displacement motor and variable displacement pump control system can have accurate regulation for movement speed, with good fine motion performance.

Electrical system

Electrical system mainly includes: engine control, monitoring instruments, auxiliary equipment, hydraulic system control, load moment limit and safety monitoring, etc. Electrical system composition: conventional electrical system and PLC control system.

Conventional electrical system includes power supply, start control, engine control and state monitoring, cab air conditioner and stereo, illumination (light), wipers and interphone. PLC control system includes the control of main/auxiliary winch, slewing gear, boom luffing, left/right crawler travel, cab rotation/tilting. All movements are through PLC logic control.

Engine system Manufacturer

Weichai Power; Model: WP17G770E302; Rated power: 566 KW; Rated speed: 2100r/min; Maximum output torque: 3000/1200-1500Nm/r/min; Type: V-type, eight cylinder, water-cooling, turbocharged and inter-cooled, direct injection diesel engine; Emission standard: comply with off-road China III standard; Fuel tank capacity: 800L.

Counterweight

Car-body counterweight is 95t: six counterweight slabs, each weighs 10t, installed in 17.5t counterweight boxes in front and rear of car-body. Turntable counterweight is 265t: two counterweight trays, each weighs 12.5t; 12 counterweight slabs on each side (left and right), each weighs 10t. Superlift counterweight is 450t: one counterweight tray of 30t; 42 counterweight slabs, each 10t.

Hook block

The configurations of hook blocks are as follows:

Name	800t	500t	50t	16t
Dead weight (t)	21	13.5	1	0.6

Notes: 800t hook is a combination hook, which can be disassembled into 400t hook. 500t hook is a combination hook, which can be disassembled into 250t hook. Optional hook block 1000t.

Centralized lubrication system

Progressive centralized lubrication system is controlled by computer programming. It can fill lubricating oil automatically point by point, so as to ensure that each point is lubricated sufficiently and make crane maintenance more easy and convenient.

Safety Protection Devices

The safety devices comprise: load moment limiter, turntable lock pin, boom backstop, hoist limit switch, anemometer, level gauge, hydraulic system overflow valve, balance valve, two-way hydraulic lock, slewing warning indicator and travel warning indicator, lightning protection device, rope over-released protection device, angle indicator, etc.

Assembly mode & working mode changeover switch

In assembly mode, over-wind protection device, boom angle limiter and load moment limiter are all out of service to facilitate crane assembly; in working mode, all safety devices work normally.

Emergency stop function

This crane has emergency stop function, all crane movements will be stopped quickly in case of emergency.

Anti-misoperation function

The handles have anti-misoperation function. A safety protection switch is set in front of the handle. If the switch is not pressed, all movement signals are shielded, and the handle will not work to prevent operation error.

Rope over-wind protection function

There is an over-wind protection device on boom head to prevent rope from being over-wound. When hoists up to a certain height, the over-wind warning light on display will be on, and load moment limiter will stop hoisting up movements at the same time.

Rope over-release protection function

Rope end limiter is set on each hoist winch to prevent wire rope from over-releasing. When there are only three loops of rope left on winch, the over-release warning light on display will be on, and the movement of lowering down will be stopped at the same time.

Ratchet locking function

Ratchet locking device is used to lock the luffing winch so that boom is stopped and placed safely at non-working state.

Slewing locking function

Slewing locking device is used to lock superstructure slewing when the crane is stopped.

Backstop function

Boom and superlift backstop devices are equipped to prevent boom and strut from tilting backward.

Boom angle limit function

When boom angle reaches the upper limit, boom raising will be stopped; when boom radius is beyond the working range, boom lowering will be stopped.

Hook latch

All lifting hooks are equipped with latch to prevent the suspended rope on the hook head from falling off.

Hydraulic system safety protection function

Hydraulic system is equipped with hydraulic balance valve, hydraulic relief valve and other devices to ensure the stable and safe work of the system.

LMI system

load moment limiter can automatically detect boom angle and lifting load. It has pre-warning function and the movement can stop automatically when overload occurs.

Audio/video alarm

It is equipped with tri-color warning light and audio/video alarm. It can display the load and movement status of the vehicle, and alert the driver and people outside the vehicle.

Illuminator light

There are illuminator lights in front of turntable, above the cab and inside the cab for lighting.

Rearview mirror

It is outside the operator's cab so that the driver can observe the situation behind the machine.

Height mark lamp

It is located on boom tip for high level operation warning.

Anemometer

It can detect the current wind speed and send signal to the monitor in operator's cab to remind the operator for safe operation in wind load.

Gradiometer

It is equipped with electronic and mechanical gradiometers, which can show the ground gradient and provide reference for the operator.

Main Technical Parameters

XGC15000A crawler crane outline dimension

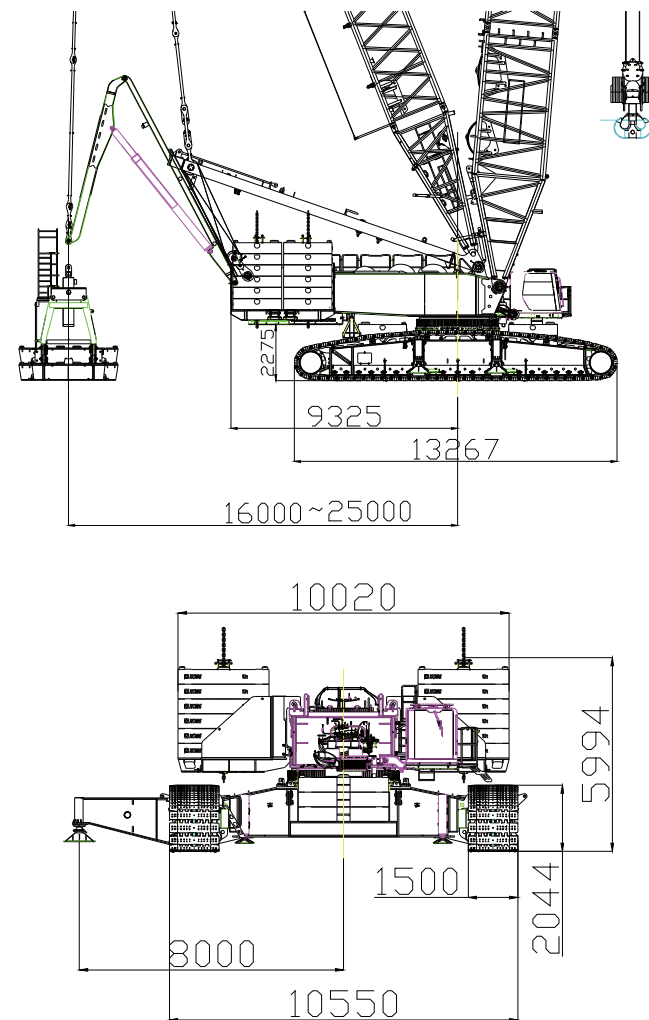

XGC15000A crawler crane outline dimension

XGC15000A crawler crane technical parameters—boom of 3.75m in width

Item		Index		Data	
Superlift working conditions	Heavy boom	Max. lifting weight	t	1000/12	
		Max. load moment	t.m	14560	
		Boom length	m	43-163	
	Light boom	Max. lifting weight	t	400	
		Boom length	m	82-172	
	Wind power jib	Single boom	Max. lifting weight	t	240
			Boom length	m	88-172
			Jib length	m	12
		Double boom	Max. lifting weight	t	240
			Boom length	m	92-172
Jib length			m	12	
Standard working conditions	Heavy boom	Max. lifting weight	t	739	
		Boom length	m	24-100	
	Light boom	Max. lifting weight	t	335	
		Boom length	m	85-103	
	Wind power jib	Max. lifting weight	t	240	
		Boom length	m	91-106	
Speed	Hoist winch max. single line speed		m/min	135	
	Boom luffing winch max. single line speed		m/min	2x55	
	Superlift luffing winch max. single line speed		m/min	135	
	Max. slewing speed		rpm	0.6	
	Max. travel speed		km/h	1.0	
Engine	Rated power		kw	556KW	
	Emission standard		-	China II	
Total crane weight (24m heavy boom, 800t hook block)			t	658	
Mean ground pressure			MPa	0.19	
Grade-ability			-	15%	
Car-body counterweight			t	95	
Turntable counterweight			t	265	
Superlift counterweight			t	450	
Max. weight of single unit in transport state—crawler tracks			t	55	
Max. weight of single unit in transport state—basic machine			t	49	
Max. dimension of single unit in transport state (L × W × H)			m	13.95 × 3.47 × 2.68	



XGC15000A CRAWLER CRANE

P09 Working Conditions

P10-11 HB-Standard heavy boom

P12-13 LB-Standard light boom

P14-19 HJ-Standard wind power jib

P20-30 SHB-Superlift heavy boom

P32-36 SHW Superlift tower jib-single boom(3.75m in width)

P37-48 SHJ-S Superlift wind power jib-single boom (3,75m in width)

Lifting Capacity Tables in Typical Working Conditions

HB-Standard heavy boom

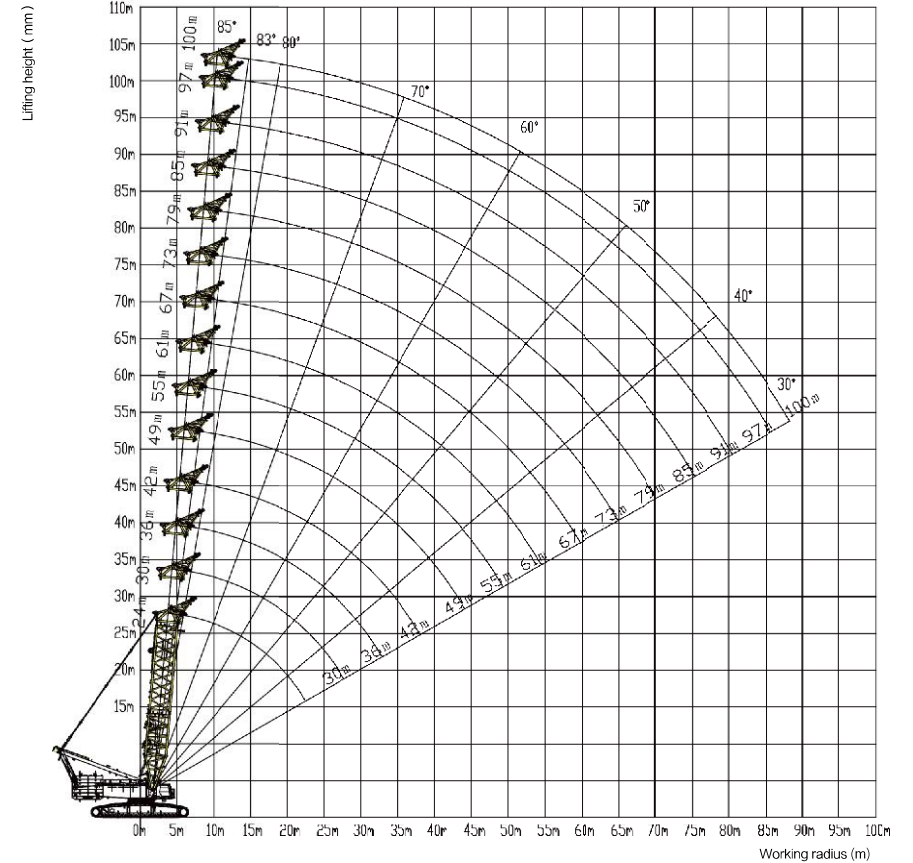
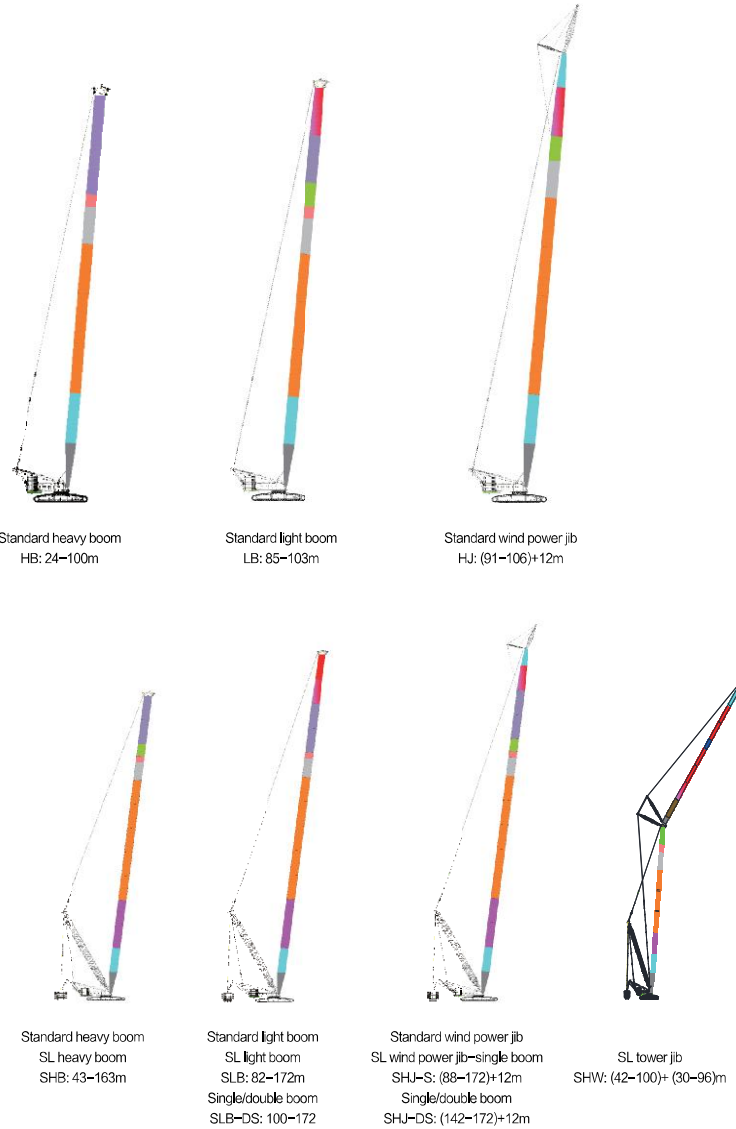

Standard heavy boom
HB: 24-100m

Lifting Capacity Tables in Typical Working Conditions

HB: standard heavy boom working condition, car-body counterweight 95t, turntable counterweight 265t

Radius (m)	HB: boom length (m)														Radius (m)
	24	30	36	42	49	55	61	67	73	79	85	91	97	100	
7	739	738	737												7
8	651	650	649	648											8
9	582	581	579	578	574	562									9
10	525	524	523	521	515	501	477	455							10
11	478	477	476	474	464	449	429	411	393	376					11
12	433	432	432	430	423	407	389	374	358	344					12
13	396	395	395	393	386	371	356	342	329	316	304	292	282	277	13
14	365	364	363	362	354	340	327	315	303	292	281	270	261	257	14
15	337	337	336	334	326	314	302	292	281	271	261	251	243	239	15
16	314	313	312	309	301	291	281	271	261	252	243	234	227	223	16
17	290	290	289	284	277	271	261	253	244	235	227	219	212	209	17
18	266	266	266	263	256	253	245	237	228	221	213	205	199	196	18
19	245	246	246	244	238	235	229	222	214	207	200	193	187	184	19
20	227	228	228	227	222	220	216	209	202	195	188	182	177	174	20
21	212	212	212	212	208	206	202	197	191	184	178	172	167	164	21
22	198	198	198	198	195	193	189	187	180	174	168	162	158	155	22
23	185	186	186	185	183	181	178	176	171	165	159	154	149	147	23
24		175	175	174	171	170	168	166	162	157	151	146	142	139	24
26		156	156	155	152	151	149	148	145	142	136	131	128	126	26
28		140	140	139	136	135	133	132	130	128	124	119	116	114	28
30			126	126	123	122	120	119	117	115	113	108	105	104	30
32			115	114	111	110	108	107	105	104	102	99	96	94	32
34				104	101	100	98	97	95	94	92	90	88	86	34
36				96	93	91	90	88	87	85	83	81	80	79	36
38				88	85	84	82	81	79	77	75	73	73	72	38
40					78	77	75	74	72	70	68	67	66	65	40

LB-Standard light boom

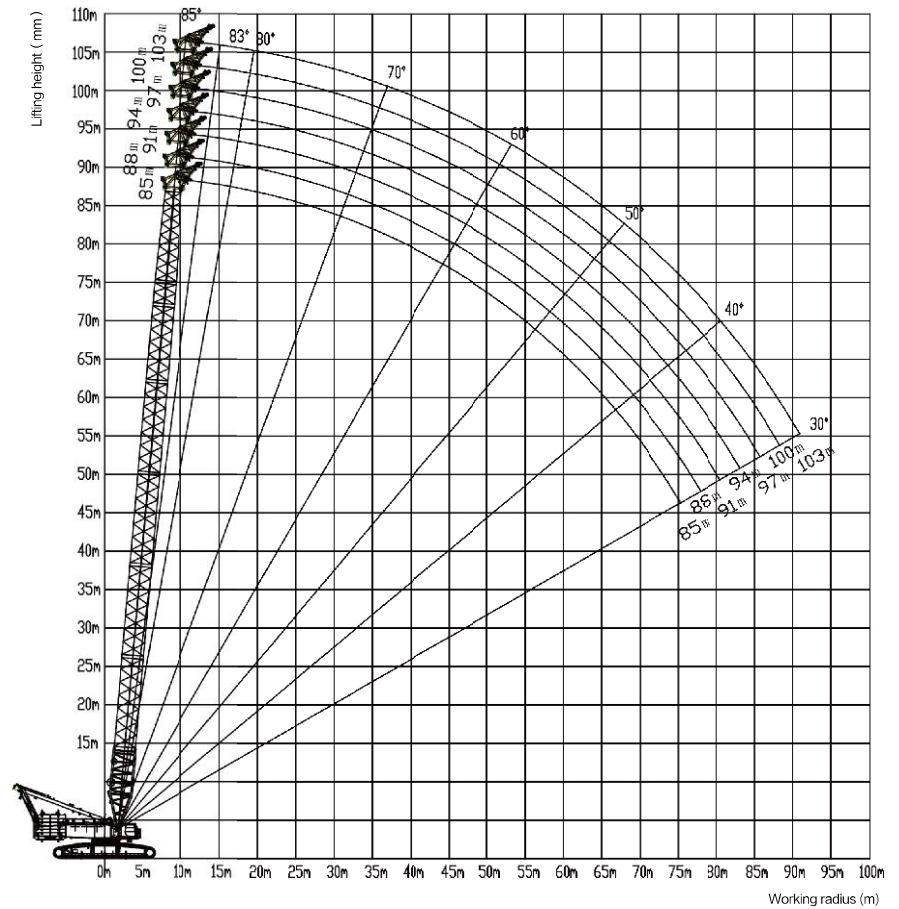

Standard light boom
LB: 85-103m

Lifting Capacity Tables in Typical Working Conditions

LB: standard light boom working condition, car-body counterweight 95t, turntable counterweight 265t

Radius (m)	LB: boom length (m)							Radius (m)
	85	88	91	94	97	100	103	
12	335	329						12
13	309	303	297	293	287	282		13
14	286	281	276	272	267	262	257	14
15	266	262	257	253	249	244	240	15
16	248	244	240	237	232	229	224	16
17	232	229	224	222	218	214	210	17
18	218	215	211	209	205	202	198	18
19	205	202	199	196	193	190	186	19
20	194	191	187	186	182	179	176	20
21	183	180	177	175	172	170	166	21
22	173	171	168	166	163	161	158	22
23	165	162	159	158	155	153	150	23
24	156	154	151	150	147	145	142	24
26	142	140	137	136	133	131	129	26
28	129	127	125	124	121	120	117	28
30	117	116	114	113	111	109	107	30
32	107	106	104	104	102	100	98	32
34	97	96	95	95	93	92	90	34
36	88	87	86	87	85	85	82	36
38	80	80	78	79	78	77	76	38
40	73	73	72	72	71	70	69	40
42	67	67	65	66	65	64	63	42
44	62	61	60	60	59	58	57	44
46	57	56	55	55	54	53	52	46
48	52	52	50	51	50	49	48	48
50	48	48	46	47	45	45	44	50

HJ-Standard wind power jib

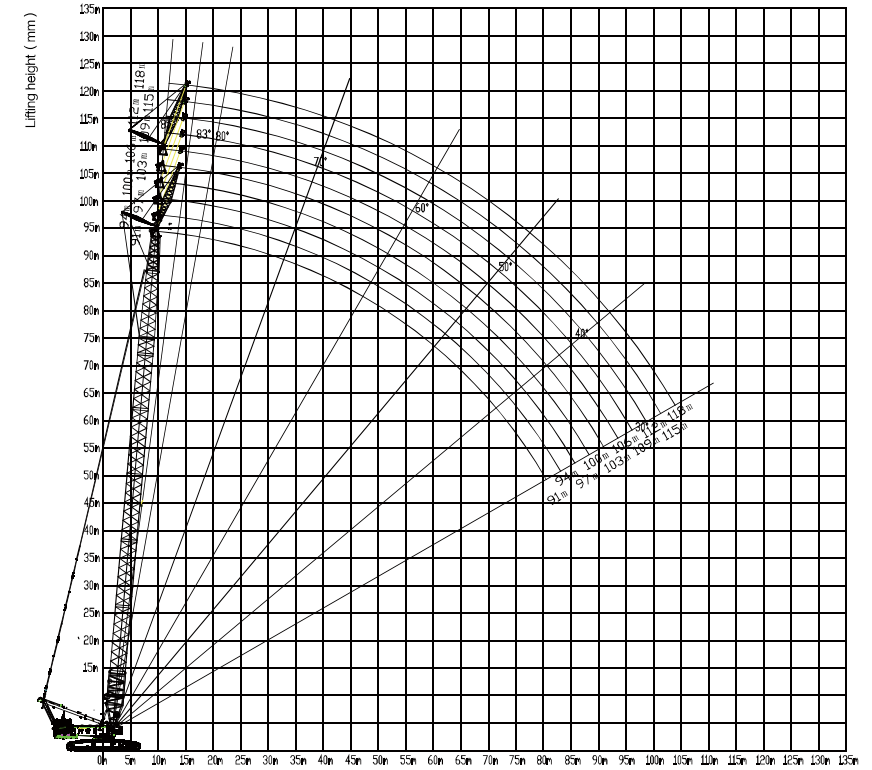

(HJ, HJ-SII, HJ-SIII) boom: 91-106m
jib: 12m (angle between boom and jib 15°)

Lifting Capacity Tables in Typical Working Conditions

HJ: standard wind power jib working condition, car-body counterweight 95t, turntable counterweight 265t, angle between boom and jib is 15°

Radius (m)	HJ: boom length (m)						Radius (m)
	91	94	97	100	103	106	
15	240	240					15
16	236	233	229	226	222		16
17	222	219	215	213	209	206	17
18	209	206	203	201	197	194	18
19	198	195	192	190	186	184	19
20	187	185	182	180	177	174	20
21	178	175	172	171	168	165	21
22	169	167	164	162	159	157	22
23	161	159	156	154	152	150	23
24	153	151	149	147	145	143	24
26	140	138	135	134	132	130	26
28	128	126	124	123	121	119	28
30	118	116	114	113	111	109	30
32	109	107	105	104	102	101	32
34	101	99	97	96	94	93	34
36	93	92	90	89	87	86	36
38	86	85	83	83	81	80	38
40	79	78	77	77	75	74	40
42	73	72	71	71	70	69	42
44	67	66	65	65	64	64	44
46	62	61	60	60	59	59	46
48	57	57	56	56	54	54	48
50	53	53	51	51	50	50	50

HJ-Standard wind power jib

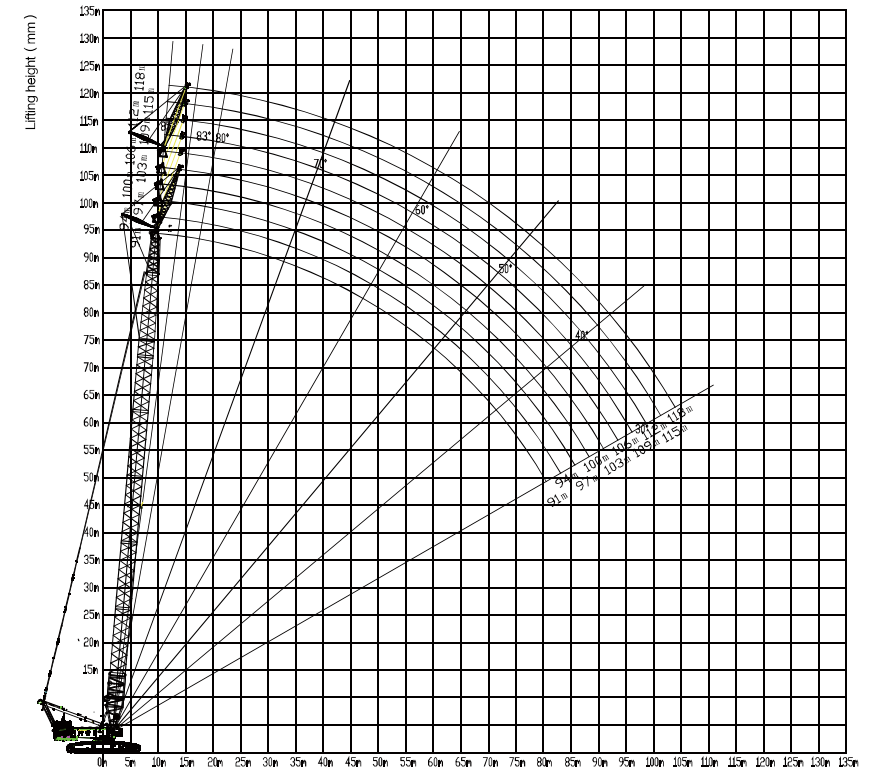

HJ boom: 91-106m
jib: 12m (angle between boom and jib 15°)

Lifting Capacity Tables in Typical Working Conditions

HJ-SII (4.5m): standard wind power jib working condition, car-body counterweight 95t, turntable counterweight 265t, strengthened counterweight 35t, angle between boom and jib is 15°

Radius (m)	boom length (m)					Radius (m)
	94	97	100	103	106	
15	240					15
16	240	240	228	224		16
17	240	240	229	221	220	17
18	232	229	226	219	217	18
19	220	217	214	210	207	19
20	209	206	203	200	197	20
21	199	195	193	190	187	21
22	189	186	184	181	178	22
23	179	177	175	172	170	23
24	170	169	167	164	162	24
26	155	153	152	150	148	26
28	142	140	139	137	136	28
30	130	128	127	126	124	30
32	120	118	117	115	114	32
34	111	109	108	106	105	34
36	102	101	100	98	97	36
38	96	93	93	91	90	38
40	90	88	87	84	83	40
42	84	82	81	80	78	42
44	78	76	76	74	73	44
46	72	71	70	69	68	46
48	67	66	66	64	63	48
50	63	61	61	60	59	

HJ-SII Standard wind power jib

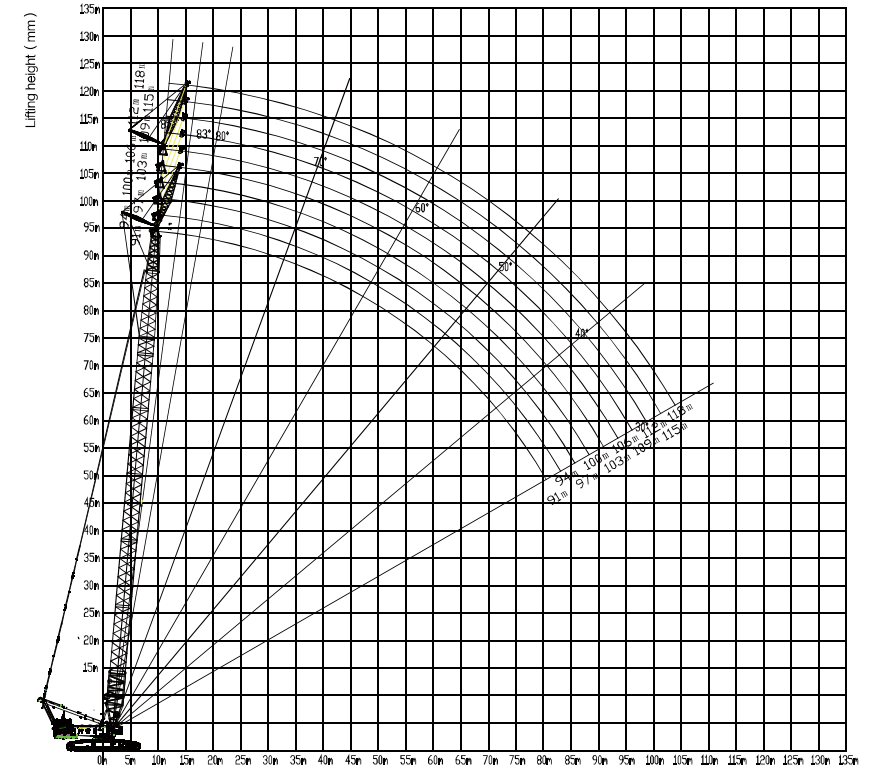

HJ-SII boom: 94-106m
jib: 12m (angle between boom and jib 15°)

Lifting Capacity Tables in Typical Working Conditions

HJ-SIV (4.5m): standard wind power jib working condition, car-body counterweight 95t, turntable counterweight 265t, strengthened counterweight 35t, angle between boom and jib is 15°

Radius (m)	LB: boom length (m)									Radius (m)
	90	93	96	99	102	105	108	111	114	
16	240	237								16
18	232	234	227	218	216	208	199	193	180	18
19	226	224	221	216	214	206	198	191	179	19
20	216	213	210	206	204	200	196	189	177	20
21	205	202	199	196	194	191	189	185	175	21
22	196	193	190	187	185	182	180	177	173	22
23	187	184	182	179	176	174	171	168	170	23
24	178	176	173	171	169	166	163	161	162	24
26	162	161	159	156	154	152	150	147	147	26
28	149	147	146	144	142	139	137	135	134	28
30	137	135	134	132	131	129	127	125	123	30
32	126	125	123	122	121	119	117	115	113	32
36	109	107	106	104	103	102	101	99	96	36
38	101	99	98	97	96	94	93	92	89	38
40	94	93	92	90	89	88	87	85	83	40
44	81	80	79	78	78	76	75	73	71	44
48	70	69	69	68	67	66	65	64	62	48
54	58	57	56	55	54	53	52	51	50	54
62	45	44	43	42	41	40	39	38	38	62
70	35	34	33	32	31	30	30	28	28	70
78	27	26	25	24	24	23	22	21	20	78
86	21	20	19	18	17	16	16	14	14	86

SHB-Superlift heavy boom

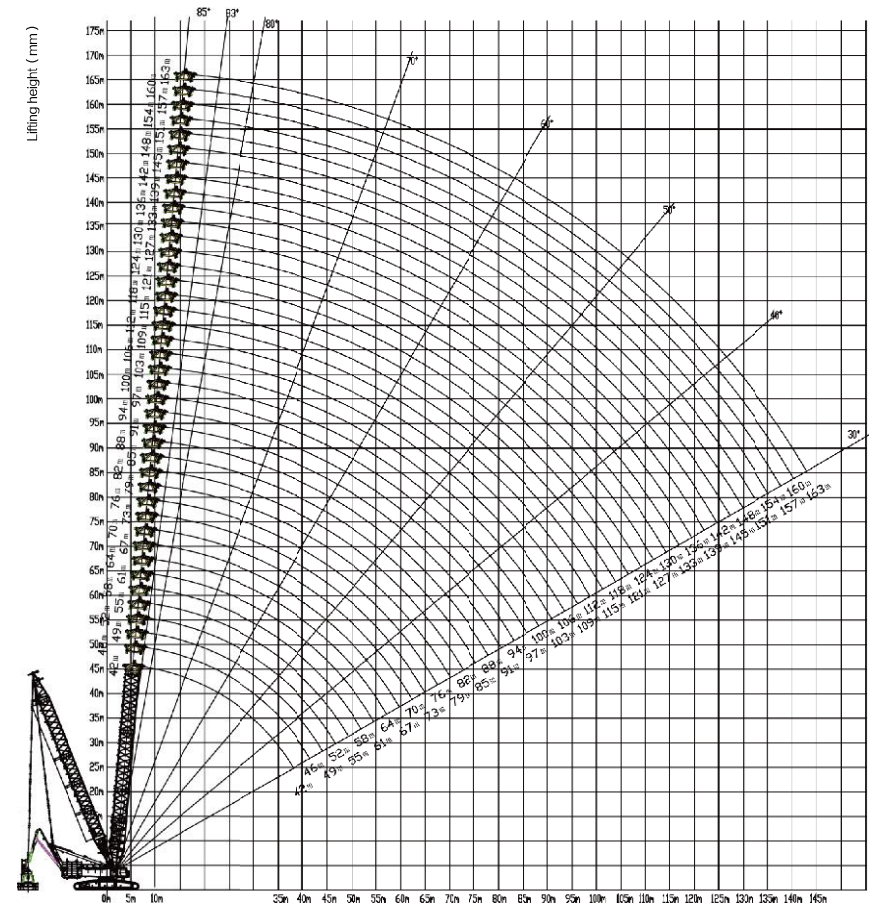

Superlift heavy boom
SHB: 42-163m

Working radius (m)

Lifting Capacity Tables in Typical Working Conditions

SHB: superlift heavy boom working condition, car-body counterweight 95t, turntable counterweight 265t, superlift mast radius 15m, superlift counterweight radius 25m (boom length: 42m)

Radius (m)	Superlift counterweight (t)								Radius (m)
	0	95	175	250	330	450	470	490	
8	701	910	932	932*	932*	932*	932*	932*	8
9	625	813	932	932*	932*	932*	932*	932*	9
10	564	734	876	932	932*	932*	932*	932*	10
12	470	613	734	846	932	932*	932*	932*	12
14	402	526	629	727	831	932*	932*	932*	14
16	344	459	550	636	728	865*	888*	911*	16
18	298	407	488	565	646	769	789	810*	18
20	262	364	438	507	581	692	710	712*	20
22	233	328	397	460	527	628	631	631*	22
24	209	295	362	420	482	564	564*	564*	24
26	189	268	332	386	443	508	508*	508*	26
28	172	245	307	357	410	459	459*	459*	28
30	157	225	283	332	381	416*	416*	416*	30
32	145	208	262	309	354	378*	378*	378*	32
34	133	193	243	289	326	344*	344*	344*	34
36	124	180	227	271	301	313*	313*	313*	36
38	111	168	212	254	278	283*	283*	283*	38

SHB: superlift heavy boom working condition, car-body counterweight 95t, turntable counterweight 265t, superlift mast radius 15m, superlift counterweight radius 25m (boom length: 46m)

Radius (m)	Superlift counterweight (t)									Radius (m)
	0	95	175	250	330	430	450	470	490	
9	616	813	970	1000	1000*	1000*	1000*	1000*	1000*	9
10	549	733	876	1000	1000*	1000*	1000*	1000*	1000*	10
11	494	668	798	921	1000	1000*	1000*	1000*	1000*	11
12	449	613	733	846	966	1000*	1000*	1000*	1000*	12
13	411	565	677	781	893	1000*	1000*	1000*	1000*	13
14	378	525	629	726	830	960	986	1000*	1000*	14
15	349	489	586	677	775	896	921	945	970	15
16	322	458	549	635	726	841	864	887	910	16
17	299	425	516	597	683	791	813	834	856	17
18	289	405	487	563	645	747	767	788	808	18
19	270	382	460	533	610	707	727	746	765	19
20	253	359	436	506	579	672	690	708	727	20
22	225	320	395	458	525	609	626	643	660	22
24	201	288	360	418	480	557	573	588	603	24
26	182	261	328	384	441	513	527	541	555	26
28	165	238	300	355	408	475	488	501	504	28
30	151	219	276	330	379	441	454	459	459	30

SHB: superlift heavy boom working condition, car-body counterweight 95t, turntable counterweight 265t, superlift counterweight 490t, superlift mast radius 15m, superlift counterweight radius 25m

Radius (m)	SHB: boom length (46-82)m												Radius (m)	
	46	49	52	55	58	61	64	67	70	73	76	79		82
9	1000*	930*	875*	824*	773*	747*	694*	667*						9
10	1000*	930*	875*	824*	773*	747*	694*	667*						10
11	1000*	930*	875*	824*	773*	747*	694*	667*	639*	612*	578*	550*		11
12	1000*	930*	875*	824*	773*	747*	694*	667*	639*	612*	578*	550*	522*	12
13	1000*	930*	875*	824*	773*	747*	694*	667*	639*	612*	578*	550*	522*	13
14	1000*	930*	875*	824*	773*	747*	694*	667*	639*	612*	578*	550*	522*	14
15	970	930*	875*	824*	773*	747*	694*	667*	639*	612*	578*	550*	522*	15
16	910	911	875*	824*	773*	747*	694*	667*	639*	612*	578*	550*	522*	16
17	856	857	856	824*	773*	747*	694*	667*	639*	612*	578*	550*	522*	17
18	808	809	809	808	773*	747*	694*	667*	639*	612*	578*	550*	522*	18
19	765	766	766	765	763	747	694*	667*	639*	612*	578*	550*	522*	19
20	727	728	727	726	724	723	694	667*	639*	612*	578*	550*	522*	20
22	660	661	660	659	657	656	655	654	639	612*	578*	550*	522*	22
24	603	604	604	603	601	600	599	598	596	595	578	550*	522*	24
26	555	557	556	555	553	552	551	550	548	547	546	541	522	26
28	504	515	515	514	512	511	510	509	507	506	505	504	494	28
30	459	478	479	478	476	475	474	473	471	470	469	468	467	30
32	419	438	448	447	445	444	443	442	440	439	438	437	435	32
34	383	402	417	419	417	416	415	414	412	411	410	409	407	34
36	351*	370	385	394	392	391	390	389	387	386	385	384	382	36
38	322*	341	356	367	370	369	368	367	365	364	363	362	360	38
40	294*	314	330	341	349	348	348	347	345	344	343	342	340	40
42	267*	289*	305	317	326	330	330	329	327	325	325	324	322	42
44		265*	282	295	304	311	313	312	310	309	308	307	305	44
46			260*	274	283	291	298	297	295	294	293	292	290	46
48				253	264	273	280	283	281	280	279	278	276	48
50				234*	246	255	263	268	267	266	265	265	263	50
52					228	238	247	253	256	255	254	253	252	52
54						222	232	238	242	244	243	242	241	54
56							217	224	228	232	233	232	230	56
58								202	210	215	220	223	221	58
60									197	203	208	212	213	60

Radius (m)	SHB: boom length (85-124)m												Radius (m)		
	85	88	91	94	97	100	103	106	109	112	115	118		121	124
12	494*	494*	465*	436*											12
13	494*	494*	465*	436*	436*	407*									13
14	494*	494*	465*	436*	436*	407*	407*	377*	377*						14
15	494*	494*	465*	436*	436*	407*	407*	377*	377*	377*	348*	348*	318*		15
16	494*	494*	465*	436*	436*	407*	407*	377*	377*	377*	348*	348*	318*	318*	16
17	494*	494*	465*	436*	436*	407*	407*	377*	377*	377*	348*	348*	318*	318*	17
18	494*	494*	465*	436*	436*	407*	407*	377*	377*	377*	348*	348*	318*	318*	18
19	494*	494*	465*	436*	436*	407*	407*	377*	377*	377*	348*	348*	318*	318*	19
20	494*	494*	465*	436*	436*	407*	407*	377*	377*	377*	348*	348*	318*	318*	20
22	494*	494*	465*	436*	436*	407*	407*	377*	377*	377*	348*	348*	318*	318*	22
24	494*	494*	465*	436*	436*	407*	407*	377*	377*	377*	348*	348*	318*	318*	24
26	494*	494*	459	436*	436*	407*	407*	377*	377*	377*	348*	348*	318*	318*	26
28	482	471	433	422	435*	407*	407*	377*	377*	377*	348*	348*	318*	318*	28
30	460	444	416	399	411*	401*	392*	377*	373*	365*	348*	348*	318*	318*	30
32	432	424	393	385	390	381*	371*	363*	354*	346*	337*	330*	318*	316*	32
34	406	400	371	364	376	362	353*	345*	337*	329*	321*	314*	306*	301*	34
36	381	378	352	345	357	350	342	329*	321*	314*	306*	300*	292*	288*	36
38	359	358	335	328	339	333	326	319	312*	300*	293*	286*	279*	276*	38
40	339	338	319	313	322	317	311	305	298	292*	285*	279*	267*	265*	40
42	321	320	302	298	307	302	296	291	285	280	274	268*	261*	259*	42
44	304	304	287	285	293	289	283	278	273	268	262	257	251*	249*	44
46	289	288	273	271	280	276	271	266	261	257	251	247	241	240	46
48	275	275	260	259	268	264	260	255	250	246	241	237	232	231	48
50	262	262	249	247	257	253	249	245	240	236	232	227	223	222	50
52	250	250	238	236	245	243	239	235	231	227	223	219	214	214	52
54	239	239	227	226	234	233	230	226	222	218	214	210	206	206	54
56	229	229	218	216	224	224	221	218	214	210	206	203	199	198	56
58	219	219	209	207	215	214	212	209	206	203	199	195	191	191	58
60	211	210	193	191	206	205	204	202	198	195	192	188	185	184	60

SHB-SII Superlift heavy boom-single boom (4.5m in width)

Radius (m)	SHB: boom length (127-163m)													Radius (m)	
	127	130	133	136	139	142	145	148	151	154	157	160	163		
16	301*	287*													16
17	301*	287*	272*	259*	245*	233*									17
18	301*	287*	272*	259*	245*	233*	221*	211*	200*						18
19	301*	287*	272*	259*	245*	233*	221*	211*	200*	191*	181*	172*	163*		19
20	301*	287*	272*	259*	245*	233*	221*	211*	200*	191*	181*	172*	163*		20
22	301*	287*	272*	259*	245*	233*	221*	211*	200*	191*	181*	172*	163*		22
24	301*	287*	272*	259*	245*	233*	221*	211*	200*	191*	181*	172*	163*		24
26	301*	287*	272*	259*	245*	233*	221*	211*	200*	191*	181*	172*	163*		26
28	301*	287*	272*	259*	245*	233*	221*	211*	200*	191*	181*	172*	163*		28
30	301*	287*	272*	259*	245*	233*	221*	211*	200*	191*	181*	172*	163*		30
32	301*	287*	272*	259*	245*	233*	221*	211*	200*	191*	181*	172*	163*		32
34	296*	287*	272*	259*	245*	233*	221*	211*	200*	191*	181*	172*	163*		34
36	283*	278*	272*	259*	245*	233*	221*	211*	200*	191*	181*	172*	163*		36
38	271*	266*	262*	257*	245*	233*	221*	211*	200*	191*	181*	172*	163*		38
40	260*	256*	251*	247*	242*	233*	221*	211*	200*	191*	181*	172*	163*		40
42	250*	245*	241*	237*	232*	229*	221*	211*	200*	191*	181*	172*	163*		42
44	245*	241*	231*	228*	223*	220*	215*	211*	200*	191*	181*	172*	163*		44
46	236*	231*	227*	223*	214*	212*	207*	204*	200*	191*	181*	172*	163*		46
48	227	223	219*	215*	211*	208*	199*	197*	193*	191*	181*	172*	163*		48
50	219	215	211	207*	203*	201*	196*	193*	186*	184*	180*	172*	162*		50
52	211	207	203	200	196	194*	189*	186*	183*	181*	178*	171*	161*		52
54	203	200	196	193	189	187	182*	180*	176*	175*	172*	168*	160*		54
56	195	192	189	186	182	180	176	174	170*	169*	166*	162*	159*		56
58	188	185	182	180	176	174	170	168	164	163	160*	157*	153*		58
60	181	179	176	173	170	168	164	162	159	158	154	152	148*		60

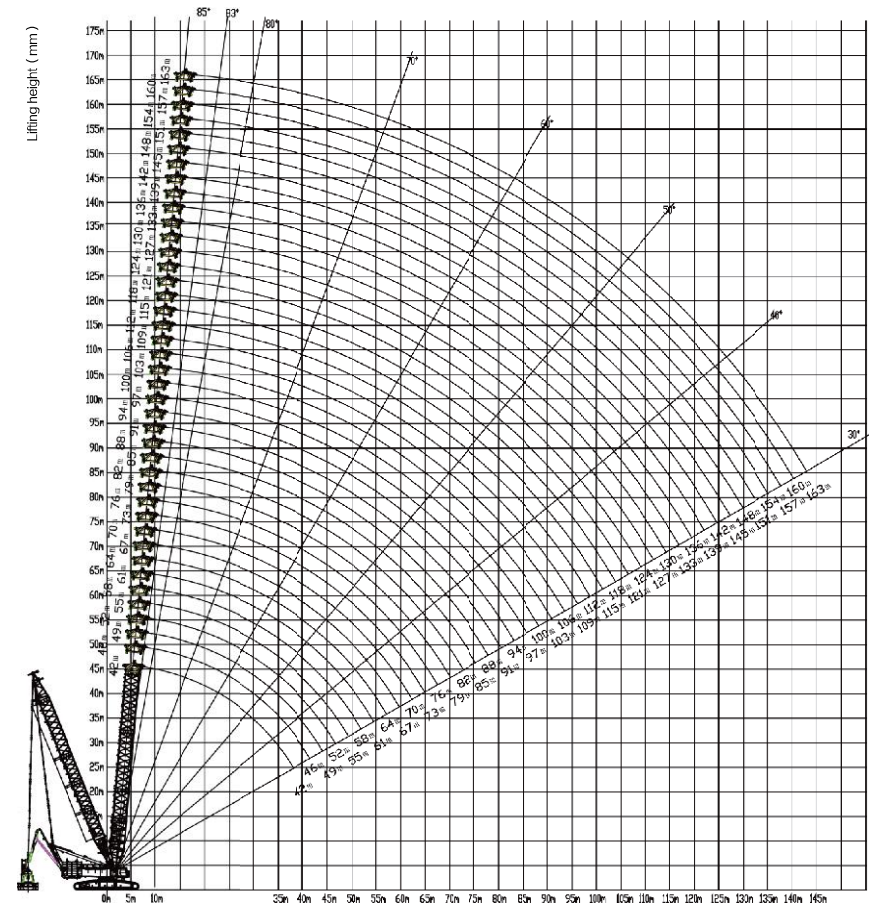

Superlift heavy boom working condition (SHB-SII) Boom length: 52-154m

Working radius (m)

Lifting Capacity Tables in Typical Working Conditions

SHB-SII: superlift heavy boom working condition, car-body counterweight 95t, turntable counterweight 265t, superlift mast radius 15m, superlift counterweight radius 25m (boom length: 52m)

Radius (m)	Superlift counterweight (t)								Radius (m)
	0	95	175	250	330	450	470	490	
9	624	843	846	846*	846*	846*	846*	846*	9
10	557	761	846	846	846*	846*	846*	846*	10
11	502	693	824	846	846*	846*	846*	846*	11
12	457	636	756	846	846*	846*	846*	846*	12
13	418	587	698	803	846	846*	846*	846*	13
14	385	544	648	746	846	846*	846*	846*	14
15	357	507	605	696	793	846*	846*	846*	15
16	332	469	566	652	743	846	846*	846*	16
18	287	406	502	578	660	783	803	824	18
20	259	365	450	519	593	703	722	740	20
22	229	325	405	470	537	638	655	672	22
24	205	292	365	429	491	584	599	615	24
26	185	265	332	394	451	537	551	566	26
28	168	242	303	361	417	497	511	524	28
30	154	222	279	333	388	462	475	487	30
32	141	204	258	308	362	432	444	451	32
34	130	189	240	287	337	403	410	417	34
36	120	176	223	268	315	374	381	387	36
38	111	164	209	251	295	348	354	361	38
40	103	153	196	235	278	325	330	336	40
44	90	135	173	209	247	283	288	289	44

SHB-SII: superlift heavy boom working condition, car-body counterweight 95t, turntable counterweight 265t, superlift mast radius 15m, superlift counterweight radius 25m (boom length: 58m)

Radius (m)	Superlift counterweight (t)								Radius (m)
	0	95	175	250	330	450	470	490	
9	611	766	766	766*	766*	766*	766*	766*	9
10	547	760	766	766*	766*	766*	766*	766*	10
11	494	692	766	766	766*	766*	766*	766*	11
12	450	635	755	766	766*	766*	766*	766*	12
13	412	586	697	766	766*	766*	766*	766*	13
14	380	543	647	745	766	766*	766*	766*	14
15	352	506	604	695	766	766*	766*	766*	15
16	327	470	565	651	742	766*	766*	766*	16
18	286	407	501	577	659	766	766	766*	18
20	251	358	447	518	592	702	721	739	20
22	229	325	405	469	536	637	654	671	22
24	205	292	365	428	490	582	598	613	24
26	185	264	332	393	450	536	550	565	26
28	168	241	303	361	416	496	509	523	28
30	153	221	279	333	387	461	474	486	30
32	140	204	258	308	361	431	442	454	32
34	129	189	239	286	337	404	415	426	34
36	119	175	223	267	315	379	390	400	36
38	110	163	208	250	295	358	368	376	38
40	102	153	195	235	277	338	345	351	40
44	89.2	134	173	209	247	297	303	308	44
48	77.9	119	154	187	222	262	267	271	48
52	68.2	106	138	168	200	231	235	235	52

Lifting Capacity Tables in Typical Working Conditions

SHB-SII: superlift heavy boom working condition, car-body counterweight 95t, turntable counterweight 265t, superlift counterweight 490t, superlift mast radius 15m, superlift counterweight radius 25m

Radius (m)	SHB-SII: boom length (52-100)m									Radius (m)
	52	58	64	70	76	82	88	94	100	
9	846*	766*								9
10	846*	766*	684*							10
11	846*	766*	684*	628*	565*					11
12	846*	766*	684*	628*	565*	507*	477*			12
13	846*	766*	684*	628*	565*	507*	477*	448*	418*	13
14	846*	766*	684*	628*	565*	507*	477*	448*	418*	14
15	846*	766*	684*	628*	565*	507*	477*	448*	418*	15
16	846*	766*	684*	628*	565*	507*	477*	448*	418*	16
18	824	766*	684*	628*	565*	507*	477*	448*	418*	18
20	740	739	684*	628*	565*	507*	477*	448*	418*	20
22	672	671	667	628	565*	507*	477*	448*	418*	22
24	615	613	610	608	565	507*	477*	448*	418*	24
26	566	565	561	560	554	507*	477*	448*	418*	26
28	524	523	519	518	514	495	470	447*	418*	28
30	487	486	482	481	477	471	443	422*	400*	30
32	451	454	450	449	445	444	423	400	379*	32
34	417	426	422	421	417	415	401	384	361	34
36	387	400	397	395	392	390	381	365	347	36
38	361	376	374	373	369	368	362	348	331	38
40	336	351	353	352	348	347	344	332	317	40
44	289	308	318	317	313	312	308	304	290	44
48		271	281	287	283	282	278	277	267	48
52		235	249	259	258	257	253	252	246	52
56			222	232	236	235	232	230	227	56
60				207	213	215	212	211	208	60
64					192	198	195	194	190	64
68					172	179	179	178	175	68
72						162	166	165	162	72
76							150	153	149	76
80								141	138	80
84								128	129	84
88									118	88

Radius (m)	SHB-SII: boom length (106-154)m									Radius (m)
	106	112	118	124	130	136	142	148	154	
14	387*									14
15	387*	357*	357*							15
16	387*	357*	357*	326*	295*					16
18	387*	357*	357*	326*	295*	295*	263*	261*		18
20	387*	357*	357*	326*	295*	295*	263*	261*	237*	20
22	387*	357*	357*	326*	295*	295*	263*	261*	237*	22
24	387*	357*	357*	326*	295*	295*	263*	261*	237*	24
26	387*	357*	357*	326*	295*	295*	263*	261*	237*	26
28	387*	357*	357*	326*	295*	295*	263*	261*	237*	28
30	382*	357*	357*	326*	295*	295*	263*	261*	237*	30
32	362*	343*	343*	313*	295*	293*	263*	261*	237*	32
34	344*	327*	327*	299*	289*	279*	263*	259*	237*	34
36	328*	311*	311*	286*	277*	266*	257*	247*	237*	36
38	317	297*	297*	273*	265*	255*	246*	237*	228*	38
40	303	288*	288*	262*	254*	244*	235*	226*	219*	40
44	279	265	265	245*	237*	225*	217*	208*	201*	44
48	257	244	244	227	219*	211*	204*	192*	186*	48
52	238	226	226	210	204	196	189*	181*	175*	52
56	220	210	210	195	189	182	175	168	162*	56
60	205	195	195	182	176	169	163	156	151	60
64	189	182	182	170	164	158	152	146	140	64
68	174	169	169	158	153	147	142	136	131	68
72	160	157	157	147	143	137	132	126	122	72
76	148	145	145	137	133	128	123	118	113	76
80	137	134	134	128	124	119	115	110	106	80
84	128	124	124	119	115	111	107	102	98.7	84
88	119	115	115	110	107	103	100	95.2	91.7	88
92	109	107	107	102	99.8	95.8	92.8	88.3	85.1	92
96		98.6	98.6	94.1	92.3	88.6	85.9	81.7	78.7	96
100				86.3	85	81.7	79.3	75.4	72.7	100
108				71	70.8	68.4	66.8	63.4	61.2	108
116						55.6	54.9	52.1	50.5	116
124							43.2	41.3	40.3	124
132									30.3	132



SHW Superlift tower jib-single boom(3.75m in width)

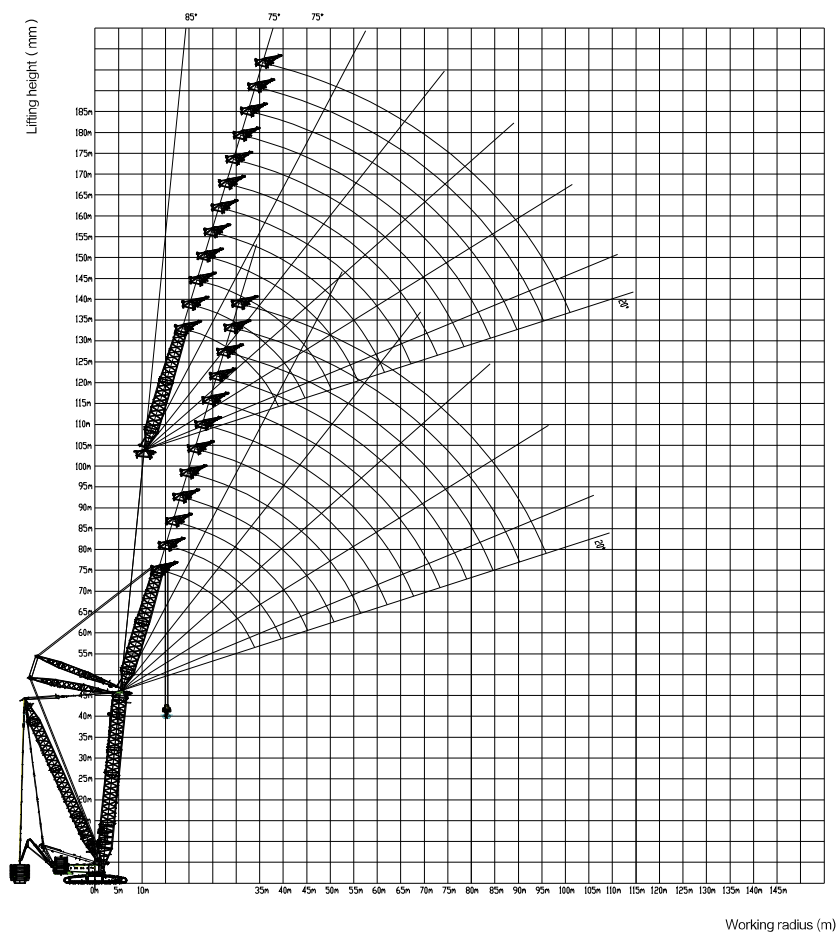

Superlift tower jib
SHW: (42-100)+(30-96)m

Lifting Capacity Tables in Typical Working Conditions

SHW: superlift tower jib working condition, car-body counterweight 95t, turntable counterweight 265t, superlift counterweight 490t, superlift mast radius 15m, superlift counterweight radius 25m (boom length: 42m)

Superlift tower jib								
Radius (m)	Jib length (30-96)							Radius (m)
	30	42	54	66	78	90	96	
17	400*							17
18	400*							18
19	400*	332*						19
20	400*	326*						20
22	400*	314*	242*					22
24	389*	299*	236*					24
26	360*	284*	229*	180*				26
28	329*	268*	221*	176*	136*			28
30	290*	252*	213*	172*	136*			30
32	256*	237*	204*	167*	134*	105*		32
34	217*	221*	195*	162*	131*	105*	93*	34
36		207*	185*	157*	128*	103*	92*	36
38		193*	176*	152*	125*	101*	91*	38
40		176*	167*	146*	122*	100*	89*	40
42		158*	158*	140*	119*	98*	88*	42
44		138*	149*	135*	115*	96*	86*	44
46			141*	129*	112*	93*	85*	46
48			133*	123*	108*	91*	83*	48
50			125*	118*	104*	89*	81*	50
52			118*	112*	101*	87*	79*	52
54			107*	107*	97*	84*	77*	54
56			95*	102*	93*	82*	75*	56
58				97*	90*	79*	73*	58
60				92*	86*	77*	71*	60
64				83*	79*	72*	67*	64
68				67*	73*	67*	63*	68
72					66*	60*	57*	72
76					58*	55*	52*	76
80						50*	47*	80
84						45*	42*	84
88						40*	38*	88
92							35*	92
96							28*	96

SHW: superlift tower jib working condition, car-body counterweight 95t, turntable counterweight 265t, superlift counterweight 490t, superlift mast radius 15m, superlift counterweight radius 25m (boom length: 67m)

Superlift tower jib								
Radius (m)	Jib length (30-96)							Radius (m)
	30	42	54	66	78	90	96	
18	373*							18
19	363*							19
20	351*							20
22	327*	271*						22
24	301*	257*	207*					24
26	276*	243*	202*					26
28	252*	228*	194*	157*				28
30	229*	212*	185*	154*	121*			30
32	208*	197*	175*	148*	121*			32
34	189*	182*	166*	143*	118*	94*		34
36	172*	168*	156*	137*	115*	94*	83*	36
38		155*	146*	131*	111*	92*	83*	38
40		143*	137*	124*	107*	90*	81*	40
42		132*	128*	118*	103*	87*	79*	42
44		121*	119*	112*	99*	85*	77*	44
46		111*	111*	105*	95*	82*	75*	46
48		102*	104*	99*	91*	79*	73*	48
50			96*	94*	87*	77*	71*	50
52			90*	88*	82*	74*	68*	52
54			83*	83*	78*	71*	66*	54
56			78*	78*	74*	68*	64*	56
58			72*	73*	70*	65*	61*	58
60				69*	67*	62*	59*	60
64				60*	60*	56*	54*	64
68				53*	53*	51*	49*	68
72					47*	46*	45*	72
76					42*	41*	40*	76
80					37*	37*	36*	80
84						33*	33*	84
88						30*	29*	88
92						26*	26*	92
96							23*	96

Lifting Capacity Tables in Typical Working Conditions

SHW: superlift tower jib working condition, car-body counterweight 95t, turntable counterweight 265t, superlift counterweight 490t, superlift mast radius 15m, superlift counterweight radius 25m (boom length: 100m)

Superlift tower jib								
Radius (m)	Jib length (30-96)							Radius (m)
	30	42	54	66	78	90	96	
22	220*							22
24	206*	176*						24
26	192*	167*						26
28	178*	158*	136*					28
30	164*	149*	130*	109*				30
32	151*	139*	123*	106*				32
34	139*	130*	117*	102*	85*			34
36	127*	120*	110*	97*	83*	68*		36
38	117*	112*	103*	93*	80*	67*	60*	38
40		103*	97*	88*	77*	65*	59*	40
42		96*	91*	83*	73*	63*	57*	42
44		88*	85*	78*	70*	60*	55*	44
46		82*	79*	74*	67*	58*	53*	46
48		75*	74*	70*	63*	56*	51*	48
50		70*	68*	65*	60*	53*	49*	50
52			64*	61*	57*	51*	47*	52
54			59*	57*	54*	48*	45*	54
56			55*	54*	51*	46*	43*	56
58			51*	50*	48*	44*	41*	58
60			48*	47*	45*	41*	39*	60
64				41*	40*	37*	35*	64
68				36*	35*	33*	31*	68
72				31*	31*	29*	28*	72
76					27*	26*	25*	76
80					24*	23*	22*	80
84					21*	20*	19*	84
88						17*	17*	88
92						15*	14*	92
96						13*	12*	96
100							11*	100

SHW: superlift tower jib working condition, car-body counterweight 95t, turntable counterweight 265t, superlift counterweight 490t, superlift mast radius 15m, superlift counterweight radius 25m (boom length: 67m)

Superlift tower jib								
Radius (m)	Jib length (30-96)							Radius (m)
	30	42	54	66	78	90	96	
18	373*							18
19	363*							19
20	351*							20
22	327*	271*						22
24	301*	257*	207*					24
26	276*	243*	202*					26
28	252*	228*	194*	157*				28
30	229*	212*	185*	154*	121*			30
32	208*	197*	175*	148*	121*			32
34	189*	182*	166*	143*	118*	94*		34
36	172*	168*	156*	137*	115*	94*	83*	36
38		155*	146*	131*	111*	92*	83*	38
40		143*	137*	124*	107*	90*	81*	40
42		132*	128*	118*	103*	87*	79*	42
44		121*	119*	112*	99*	85*	77*	44
46		111*	111*	105*	95*	82*	75*	46
48		102*	104*	99*	91*	79*	73*	48
50			96*	94*	87*	77*	71*	50
52			90*	88*	82*	74*	68*	52
54			83*	83*	78*	71*	66*	54
56			78*	78*	74*	68*	64*	56
58			72*	73*	70*	65*	61*	58
60				69*	67*	62*	59*	60
64				60*	60*	56*	54*	64
68				53*	53*	51*	49*	68
72					47*	46*	45*	72
76					42*	41*	40*	76
80					37*	37*	36*	80
84						33*	33*	84
88						30*	29*	88
92						26*	26*	92
96							23*	96

典型工况起重性能表

SHJ-S Superlift wind power jib-single boom (3.75m in width)

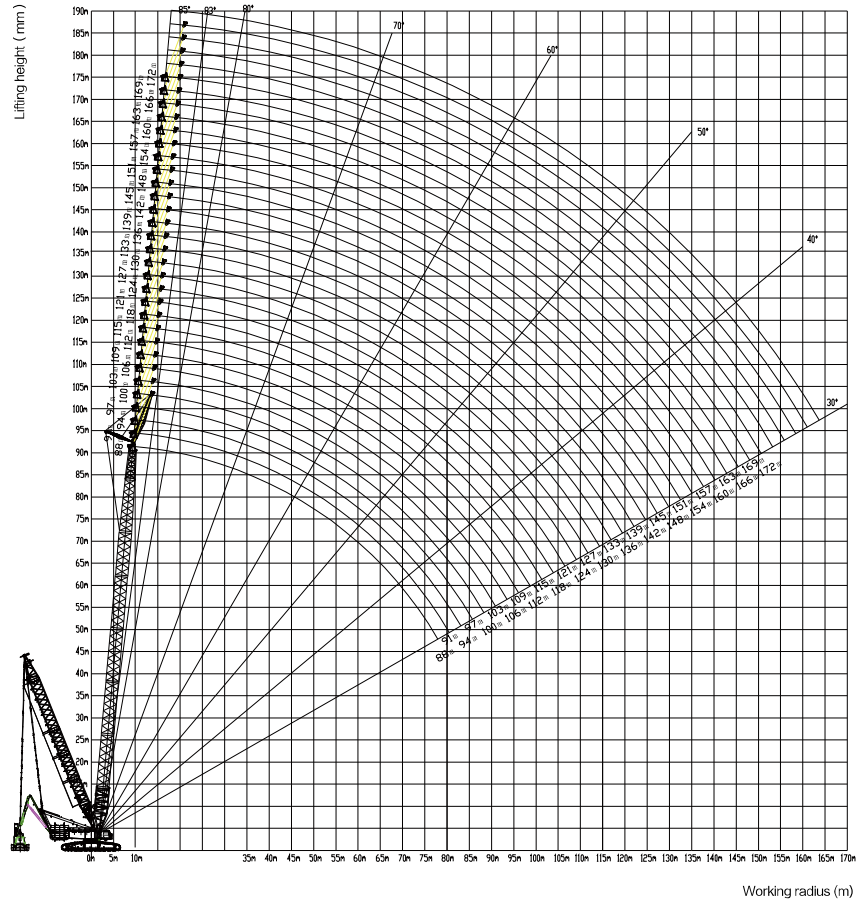

Superlift wind power jib (angle between boom and jib 15°)
 Boom length: 88-172m, jib: 12m

SHJ-S: superlift wind power jib working condition, angle between boom and jib 15° , car-body counterweight 95t, turntable counterweight 265t, superlift counterweight 430t, superlift mast radius 15m, superlift counterweight radius 16m

Radius (m)	SHJ-S: Boom length (88-115)m										Radius (m)
	88	91	94	97	100	103	106	109	112	115	
15	240*	240*	240*								15
16	240*	240*	240*	240*	240*	240*					16
17	240*	240*	240*	240*	240*	240*	240*	240*	240*	240*	17
18	237*	239*	240*	240*	240*	240*	240*	240*	240*	240*	18
19	231*	233*	236*	238*	239*	240*	240*	240*	240*	240*	19
20	226*	228*	230*	232*	234*	236*	238*	240*	240*	240*	20
21	221*	223*	225*	227*	229*	231*	233*	235*	237*	238*	21
22	216*	218*	220*	222*	224*	226*	228*	230*	232*	234*	22
23	211*	213*	216*	218*	220*	222*	224*	226*	227*	229*	23
24	206*	209*	211*	213*	215*	217*	219*	221*	223*	225*	24
26	198*	200*	203*	205*	207*	209*	211*	213*	215*	217*	26
28	190*	193*	195*	197*	199*	201*	203*	205*	207*	209*	28
30	183*	185*	188*	190*	192*	194*	196*	198*	200*	202*	30
32	176*	179*	181*	183*	186*	188*	190*	192*	194*	196*	32
34	170*	173*	175*	177*	179*	182*	184*	186*	188*	190*	34
36	165*	167*	169*	172*	174*	176*	178*	180*	182*	184*	36
38	159*	162*	164*	166*	168*	170*	173*	175*	177*	178*	38
40	154*	157*	159*	161*	163*	165*	168*	170*	171*	173*	40
42	150*	152*	154*	156*	159*	161*	163*	165*	167*	169	42
44	145*	148*	150*	152*	154*	156*	158*	160	162	164	44
46	141*	143*	146*	148*	150*	152	154	156	158	160	46
48	137*	140*	142*	144*	146	148	150	152	154	156	48
50	134*	136*	138	140	142	144	146	148	150	152	50

Lifting Capacity Tables in Typical Working Conditions

SHJ-S: superlift wind power jib working condition, angle between boom and jib 15° , car-body counterweight 95t, turntable counterweight 265t, superlift counterweight 0t, superlift mast radius 15m, superlift counterweight radius 16m

Radius (m)	SHJ-S: Boom length (88-115)m										Radius (m)
	88	91	94	97	100	103	106	109	112	115	
15	240	240	240								15
16	240	240	240	240	240	240					16
17	240	240	240	240	240	240	240	240	238	234	17
18	237	239	240	240	239	235	232	229	225	221	18
19	231	233	234	231	226	223	220	216	213	210	19
20	226	225	222	219	215	211	209	205	202	199	20
21	217	214	211	208	204	201	198	195	192	189	21
22	207	203	201	198	194	191	189	186	183	180	22
23	197	194	191	188	185	182	180	177	174	171	23
24	188	185	183	180	177	174	172	169	166	163	24
26	172	169	167	164	161	159	157	154	152	149	26
28	158	155	154	151	148	146	144	141	139	137	28
30	146	143	142	139	136	134	132	130	128	125	30
32	135	133	131	129	126	124	122	120	118	116	32
34	125	123	121	119	117	115	113	111	109	107	34
36	117	114	113	111	108	106	105	103	101	99	36
38	104	107	105	103	101	99	97	95	94	92	38
40	96	95	94	96	94	92	91	89	87	85	40
42	88	87	87	86	88	86	85	83	81	79	42
44	82	81	81	80	78	80	79	77	75	74	44
46	76	75	75	74	72	71	74	72	70	68	46
48	71	70	70	69	67	66	66	67	66	64	48
50	66	65	65	64	62	61	61	60	61	59	50

SHJ-S: superlift wind power jib working condition, angle between boom and jib 15° , car-body counterweight 95t, turntable counterweight 265t, superlift counterweight 430t, superlift mast radius 15m, superlift counterweight radius 16m

Radius (m)	SHJ-S: Boom length (118-145)m										Radius (m)
	118	121	124	127	130	133	136	139	142	145	
18	240*	236*	235*								18
19	240*	236*	235*	229*	222*	212*	206*				19
20	240*	236*	235*	229*	222*	212*	206*	197*	188*	181*	20
21	240*	236*	235*	229*	222*	212*	206*	197*	188*	181*	21
22	235*	236*	235*	229*	222*	212*	206*	197*	188*	181*	22
23	231*	233*	234*	229*	222*	212*	206*	197*	188*	181*	23
24	227*	228*	230*	229*	222*	212*	206*	197*	188*	181*	24
26	219*	220*	222*	229*	222*	212*	206*	197*	188*	181*	26
28	211*	213*	215*	228*	222*	212*	206*	197*	188*	181*	28
30	204*	206*	208*	221*	222*	212*	206*	197*	188*	181*	30
32	198*	199*	201*	214*	217*	212*	206*	197*	188*	181*	32
34	191*	193*	195*	208*	211*	212*	206*	197*	188*	181*	34
36	186*	188*	189*	203	205	208	206	197	188*	181*	36
38	180*	182*	184*	197	200	203	205	197	188	181	38
40	175*	177	179	192	195	198	200	197	188	181	40
42	171	172	174	188	190	193	195	197	188	181	42
44	166	168	170	183	186	189	191	194	188	181	44
46	162	164	165	179	182	185	187	190	188	181	46
48	158	160	161	175	178	181	183	181	181	181	48
50	154	156	157	171	174	174	173	172	171	172	50

Lifting Capacity Tables in Typical Working Conditions

SHJ-S: superlift wind power jib working condition, angle between boom and jib 15° , car-body counterweight 95t, turntable counterweight 265t, superlift counterweight 0t, superlift mast radius 15m, superlift counterweight radius 16m

Radius (m)	SHJ-S: Boom length (118-145)m										Radius (m)
	118	121	124	127	130	133	136	139	142	145	
18	218	215	212								18
19	207	203	200	196	194	191	188				19
20	196	193	190	186	184	181	178	175	172	171	20
21	186	183	181	177	175	172	169	166	164	162	21
22	177	174	172	168	166	163	161	158	155	154	22
23	169	166	164	160	158	155	153	150	148	147	23
24	161	158	156	152	150	148	145	143	141	140	24
26	147	145	142	139	137	134	132	130	128	127	26
28	135	132	130	127	125	123	121	118	117	115	28
30	124	121	119	116	115	112	110	108	106	105	30
32	114	112	110	107	105	103	101	99	97	96	32
34	105	103	101	98	97	94	93	90	89	88	34
36	97	95	94	90	89	87	85	83	82	80	36
38	90	88	87	83	82	80	78	76	75	74	38
40	84	82	80	77	76	74	72	70	69	67	40
42	78	76	74	71	70	68	66	64	63	62	42
44	72	70	69	66	64	62	61	59	58	57	44
46	67	65	64	61	59	58	56	54	53	52	46
48	63	61	59	56	55	53	52	50	49	47	48
50	58	57	55	52	51	49	47	45	44	43	50

SHJ-S: superlift wind power jib working condition, angle between boom and jib 15° , car-body counterweight 95t, turntable counterweight 265t, superlift counterweight 430t, superlift mast radius 15m, superlift counterweight radius 16m

Radius (m)	SHJ-S: Boom length (148-172)m									Radius (m)
	148	151	154	157	160	163	166	169	172	
21	173*	165*	155*	150*						21
22	173*	165*	155*	150*	142*	137*	131*			22
23	173*	165*	155*	150*	142*	137*	131*	125*	119*	23
24	173*	165*	155*	150*	142*	137*	131*	125*	119*	24
26	173*	165*	155*	150*	142*	137*	131*	125*	119*	26
28	173*	165*	155*	150*	142*	137*	131*	125*	119*	28
30	173*	165*	155*	150*	142*	137*	131*	125*	119*	30
32	173*	165*	155*	150*	142*	137*	131*	125*	119*	32
34	173*	165*	155*	150*	142*	137*	131*	125*	119*	34
36	173*	165*	155*	150*	142*	136*	130*	125*	119*	36
38	173*	165*	155*	150*	142*	136*	130*	123*	117*	38
40	173	165	155*	150*	142*	136*	130*	123*	117*	40
42	173	165	155	150	142*	136*	130*	123*	117*	42
44	173	165	155	150	142	136*	130*	123*	117*	44
46	173	165	155	150	142	136	130	123*	117*	46
48	173	165	155	150	142	136	130	123	117*	48
50	172	163	155	150	142	136	130	123	117	50

Lifting Capacity Tables in Typical Working Conditions

SHJ-S: superlift wind power jib working condition, angle between boom and jib 15°, car-body counterweight 95t, turntable counterweight 265t, superlift counterweight 0t, superlift mast radius 15m, superlift counterweight radius 16m

Radius (m)	SHJ-S: Boom length (148-172)m									Radius (m)
	148	151	154	157	160	163	166	169	172	
21	161	165	155	150						21
22	153	160	148	145	142	137	131			22
23	146	151	141	138	135	132	130	125	119	23
24	139	144	134	131	128	125	123	121	119	24
26	126	129	121	119	116	113	112	109	109	26
28	115	116	110	108	106	103	101	99	99	28
30	105	105	101	98	96	93	92	90	89	30
32	96	94	92	90	87	85	83	81	81	32
34	87	85	84	82	80	77	76	74	74	34
36	80	76	77	75	73	70	69	67	67	36
38	73	69	70	68	66	64	63	61	61	38
40	67	62	64	62	60	58	57	55	55	40
42	62	55	58	56	55	53	51	49	50	42
44	56	49	53	51	50	48	46	45	45	44
46	52	43	48	47	45	43	42	40	40	46
48	47	38	44	42	41	39	38	36	36	48
50	43	33	40	38	37	35	34	32	32	50

SHJ-SII12 Superlift wind power jib- single boom (4.5m in width)

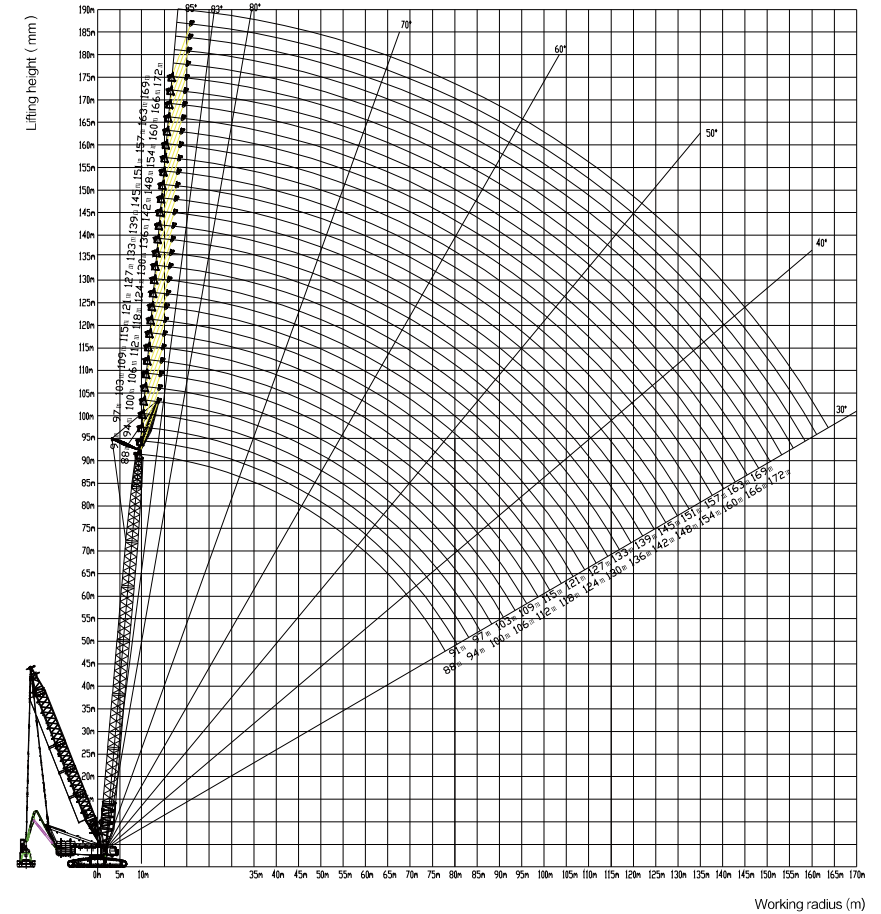

Superlift wind power jib (angle between boom and jib 15°)
 Boom length: 106-172m, jib: 12m

Lifting Capacity Tables in Typical Working Conditions

SHJ-SII12: superlift wind power jib working condition, angle between boom and jib 15° , car-body counterweight 95t, turntable counterweight 265t, superlift counterweight 430t, superlift mast radius 15m, superlift counterweight radius 16m

Radius (m)	SHJ-SII12: Boom length (118–145)m										Radius (m)
	118	121	124	127	130	133	136	139	142	145	
18	240*	240*	240*								18
19	240*	240*	240*	240*	240*	240*	240*				19
20	239*	240*	240*	240*	240*	240*	240*	235*	236*	228*	20
21	234*	240*	240*	240*	240*	240*	240*	235*	236*	228*	21
22	230*	240*	240*	240*	240*	240*	240*	235*	236*	228*	22
23	225*	236*	238*	240*	240*	240*	240*	235*	236*	228*	23
24	221*	232*	234*	237*	238*	240*	240*	235*	236*	228*	24
26	213*	224*	226*	229*	231*	233*	236*	235*	236*	228*	26
28	206*	216*	219*	222*	224*	226*	229*	232*	233*	228*	28
30	199*	210*	212*	215*	217*	220*	222*	225*	227*	228*	30
32	193*	203*	206*	209*	211*	213*	216*	219*	221*	225*	32
34	187*	197*	200*	203*	205*	208*	210*	213	215	219	34
36	181*	192*	195*	197*	199	202	205	208	210	214	36
38	176*	186	189	192	194	197	200	203	205	209	38
40	171*	182	184	187	189	192	195	198	200	204	40
42	166	177	180	183	185	187	190	193	195	199	42
44	162	172	175	178	180	183	186	189	191	195	44
46	158	168	171	174	176	179	182	185	187	186	46
48	154	164	167	170	172	175	178	179	177	176	48
50	150	161	163	166	168	171	170	169	168	166	50

SHJ-SII12: superlift wind power jib working condition, angle between boom and jib 15° , car-body counterweight 95t, turntable counterweight 265t, superlift counterweight 0t, superlift mast radius 15m, superlift counterweight radius 16m

Radius (m)	SHJ-SII12: Boom length (118–145)m										Radius (m)
	118	121	124	127	130	133	136	139	142	145	
18	216	212	209								18
19	205	200	198	194	191	188	185				19
20	194	190	187	184	181	178	175	172	169	166	20
21	184	180	178	175	172	169	166	163	160	157	21
22	175	171	169	166	163	160	158	155	152	149	22
23	167	163	161	158	155	152	150	147	144	142	23
24	159	155	153	150	147	145	143	140	137	135	24
26	145	141	139	137	134	131	130	127	124	122	26
28	132	129	127	124	122	120	118	115	113	111	28
30	121	118	116	114	111	109	108	105	103	101	30
32	111	108	106	104	102	100	98	96	94	92	32
34	103	99	98	96	93	91	90	88	86	83	34
36	95	91	90	88	86	84	82	80	78	76	36
38	87	84	83	81	79	77	75	73	71	69	38
40	81	78	76	74	72	70	69	67	65	63	40
42	75	72	70	69	67	65	63	62	60	58	42
44	69	66	65	63	61	59	58	56	54	52	44
46	64	61	60	58	56	54	53	51	50	48	46
48	60	56	55	54	52	50	49	47	45	43	48
50	55	52	51	49	47	46	45	43	41	39	50

Lifting Capacity Tables in Typical Working Conditions

SHJ-SII12: superlift wind power jib working condition, angle between boom and jib 15°, car-body counterweight 95t, turntable counterweight 265t, superlift counterweight 430t, superlift mast radius 15m, superlift counterweight radius 16m

Radius (m)	SHJ-SII12: Boom length (148-172)m									Radius (m)
	148	151	154	157	160	163	166	169	172	
21	224*	217*	213*	207*						21
22	224*	217*	213*	207*	203*	191*	190*			22
23	224*	217*	213*	207*	202*	191*	190*	183*	181*	23
24	224*	217*	213*	207*	201*	191*	189*	182*	180*	24
26	224*	217*	213*	207*	199*	191*	188*	181*	179*	26
28	224*	217*	213*	202*	198*	191*	186*	179*	178*	28
30	221*	212*	210*	202*	195*	186*	184*	175*	176*	30
32	221*	212*	207*	201*	193*	186*	181*	175*	174*	32
34	218	211	204	194*	189*	183*	179*	173*	172*	34
36	215	207	201	194	187	181*	177*	171*	170*	36
38	211	204	198	189	184	178	175	169	164*	38
40	207	200	194	189	181	172	172	167	164	40
42	198	196	192	186	178	172	169	161	163	42
44	197	188	187	179	175	170	166	161	161	44
46	186	184	178	175	167	167	164	159	156	46
48	175	174	168	166	165	164	158	153	156	48
50	166	164	158	157	156	154	154	151	151	50

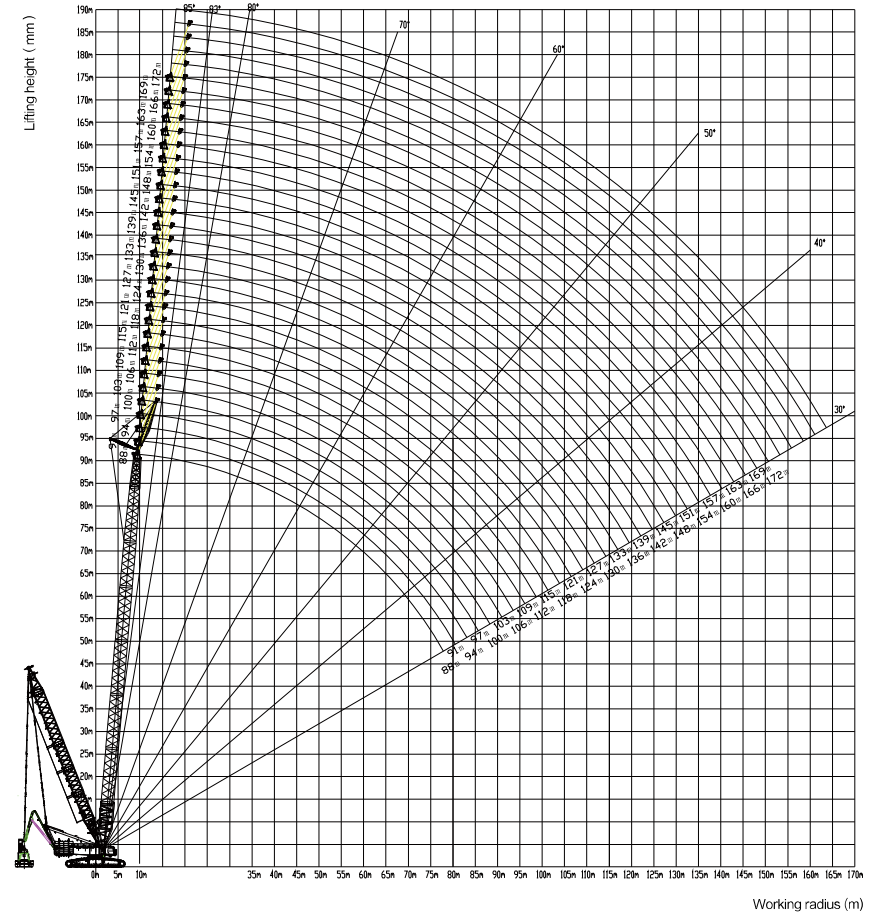

49

XGC15000A CRAWLER CRANE

P50-60 Transport Plan

Transport Plan

Transport weight and dimension of main parts n of XGC15000A crawler crane

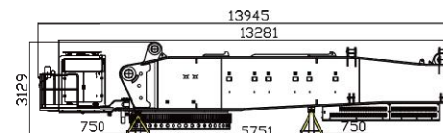

Basic machine I × 1

L	13.945 m
W	3.468 m
H	2.678 m
W	49 t

Include turntable, cab, turntable hydraulic system, power system and etc.

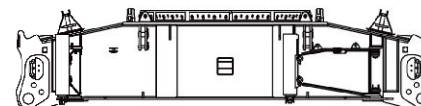

Basic machine II × 1

L	8.304 m
W	3.889 m
H	2.025 m
W	36.5 t

Include car-body, cylinder, outrigger pads

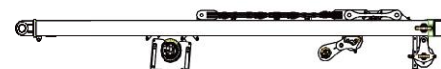

Mast assembly × 1

L	13.632 m
W	2.12 m
H	1.668 m
W	22 t

main luffing system, main luffing sheave block, self-assembly cylinder, pendants and etc.



Left track frame × 1

L	13.337 m
W	1.5 m
H	2.035 m
W	54.6 t



Right track frame × 1

L	13.337 m
W	1.5 m
H	2.035 m
W	55 t

Transport Plan

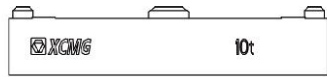

Counterweight block	× 74
L	2.75 m
W	2.0 m
H	0.54 m
W	10 t

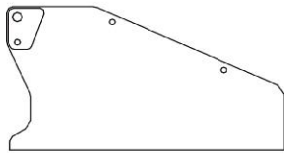

Car-body counterweight box	× 2
L	3.36 m
W	2.61 m
H	2.34 m
W	17.5 t

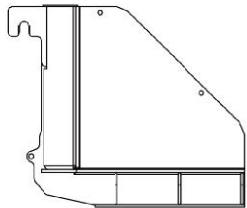

Turntable counterweight box	× 2
L	4.25 m
W	3.00 m
H	2.34 m
W	13.5 t



Turntable counterweight locking chain	× 1
L	m
W	m
H	m
W	t

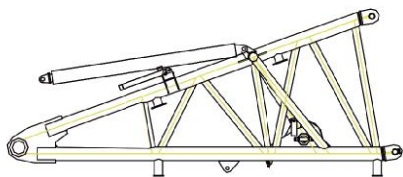

Superlift mast butt	× 4
L	6.4 m
W	3.15 m
H	2.67 m
W	6.85 t

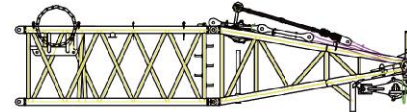

Integrated transport components of superlift mast	× 1
L	12.42 m
W	3.74 m
H	3.337 m
W	20.97 t

Include 6m superlift mast insert, superlift mast luffing system, superlift luffing sheave block, superlift mast top, pendants and etc.

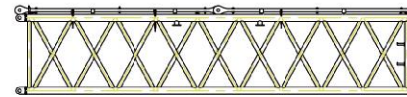

12m superlift mast insert	× 1
L	12.29 m
W	2.735 m
H	2.675 m
W	8.95 t

include pendant

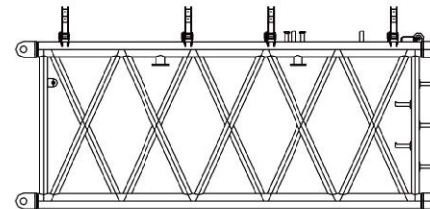

6m superlift mast insert	× 2
L	6.23 m
W	2.74 m
H	2.93 m
W	5.78 t

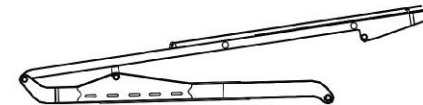

Superlift counterweight pushing device	× 6
L	9.62 m
W	4.1 m
H	2.3 m
W	10.73 t

Include bracket and two cylinders

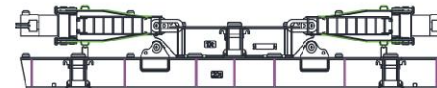

Superlift counterweight tray	× 1
L	11.6 m
W	3.0 m
H	1.77 m
W	33 t

Include lifting cylinder and bracket

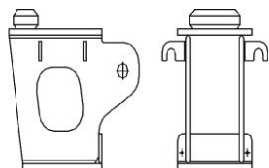

Superlift counterweight tray ■	× 6
L	0.75 m
W	0.72 m
H	0.75 m
W	0.32 t

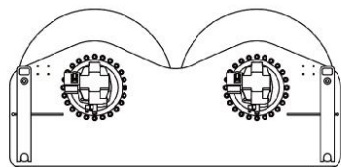

Main hoist winch	× 1
L	2.57 m
W	2.25 m
H	1.26 m
W	16.5 t

Include wire rope

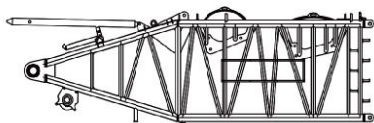

Boom butt	× 1
L	10,885 m
W	3.29 m
H	3.408 m
W	16.8 t

Include two backstop cylinders and reeving winch

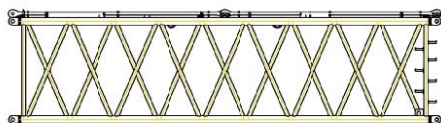

12m heavy-duty boomtransition section	× 1
L	12,250 m
W	3,730 m
H	3,246 m
W	13.5 t

Include pendant

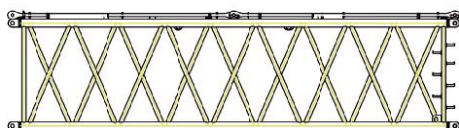

12m heavy-duty boominsert A	× 2
L	12,250 m
W	3,730 m
H	3,246 m
W	13.7 t

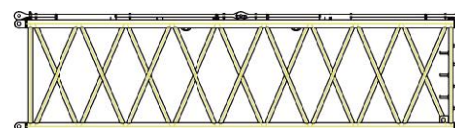

12m heavy-duty boominsert B	× 2
L	12,250 m
W	3,730 m
H	3,246 m
W	13,0 t

Include pendant

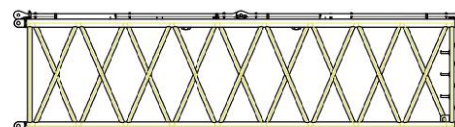

12m heavy-duty boominsert-center hitch	× 1
L	12,250 m
W	3,730 m
H	3,246 m
W	11,42 t

Include pendant

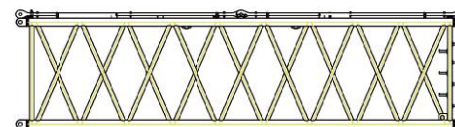

12m heavy-duty boominsert C	× 2
L	12,250 m
W	3,730 m
H	3,246 m
W	11,50 t

Include pendant

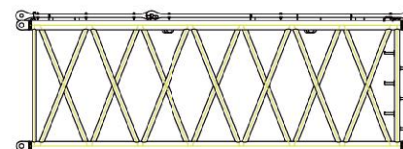

10m boomtransition section	× 1
L	10,250 m
W	3,730 m
H	3,246 m
W	9.6 t

Include pendant

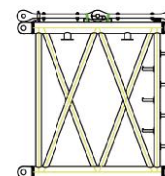

3m boominsert	× 1
L	3.25 m
W	3,235 m
H	3,171 m
W	3.25 t

Include pendant

Transport Plan

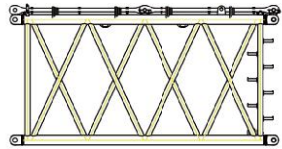

6m boominsert	× 1
L	6.25 m
W	3.29 m
H	3.25 m
W	5.43 t

Include pendant

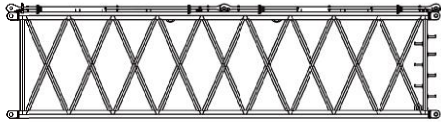

12m boomtop (include sliding rail of tower jib rear strut backstop device)	× 1
L	12.23 m
W	3.29 m
H	3.25 m
W	9.51 t

Include pendant

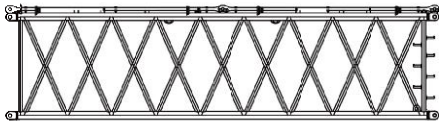

12m boominsert A	× 1
L	12.23 m
W	3.29 m
H	3.25 m
W	10.54 t

Include pendant

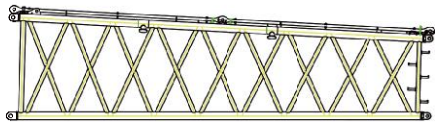

12m boomtransition section	× 1
L	12.26 m
W	3.23 m
H	3.178 m
W	7.76 t

Include pendant

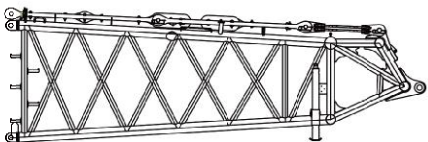

7.5m wind power boomtop	× 1
L	8.517 m
W	2.54 m
H	2.679 m
W	6.144 t

Include pendant

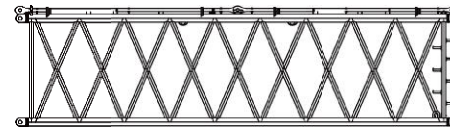

12m boominsert B	× 1
L	12.23 m
W	3.29 m
H	3.25 m
W	8.59 t

Include pendant



12m wind power jib	× 1
L	12.771 m
W	2.54 m
H	2.679 m
W	6.144 t

Include pendant

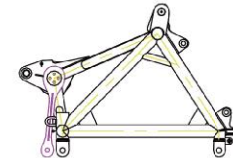

Heavy-duty boomhead	× 1
L	4.01 m
W	3.41 m
H	2.75 m
W	6.82 t

Include pendant

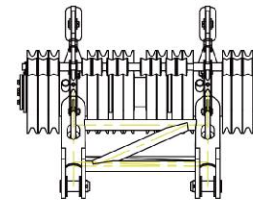

Boom head sheave block	× 2
L	1.831 m
W	1.43 m
H	1.644 m
W	2.1 t

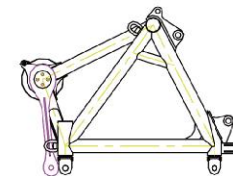

Light-duty boom head	× 1
L	2.79 m
W	2.42 m
H	6.9 m
W	2.79 t

Transport Plan

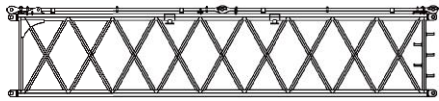

12m boominsert-rear pendant × 1

L	12.225 m
W	2.7 m
H	2.70 m
W	6.20 t

Include pendant

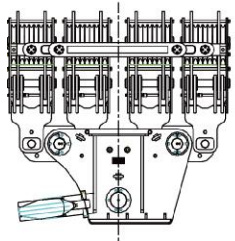

800t capacity hook block × 1

L	4.846 m
W	3.77 m
H	1.09 m
W	20.88 t

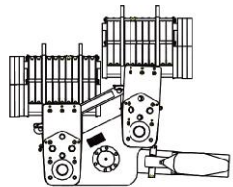

500t capacity hook block × 1

L	2.73 m
W	1.78 m
H	2.29 m
W	13.5 t

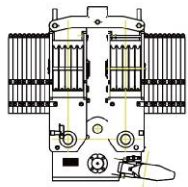

240t capacity hook block × 1

L	2.352 m
W	1.062 m
H	2.33 m
W	9.2 t

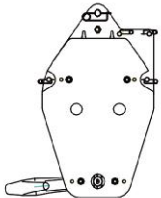

50t capacity hook block × 1

L	1.01 m
W	0.64 m
H	1.32 m
W	2.5 t

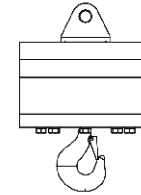

16t capacity hook block × 1

L	0.6 m
W	0.6 m
H	0.87 m
W	0.88 t

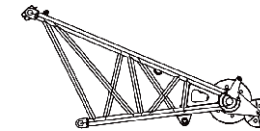

Boom single top × 1

L	3.39 m
W	1.14 m
H	1.66 m
W	0.78 t

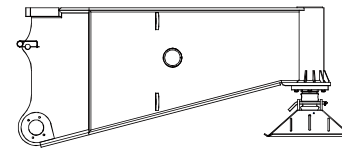

Side outriggers × 1

L	3.6 m
W	1.33 m
H	1.5 m
W	2.7 t

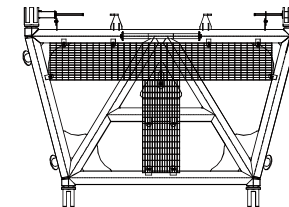

3m boominsert W1 × 1

L	3.23 m
W	3.29 m
H	3.25 m
W	6.96 t

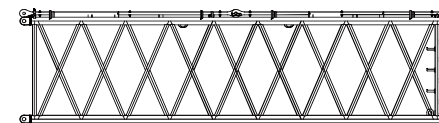

12m boominsert W2 × 3

L	12.23 m
W	4.43 m
H	3.25 m
W	13.23 t

Include pendant

Transport Plan

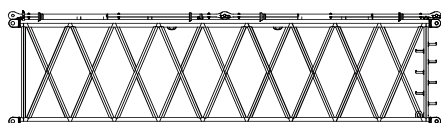

12m boominsert W3	× 1
L	12.23 m
W	4.43 m
H	3.25 m
W	13.32 t

Include pendant

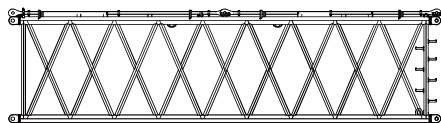

12m boominsert W4	× 2
L	12.23 m
W	4.43 m
H	3.25 m
W	11.77 t

Include pendant

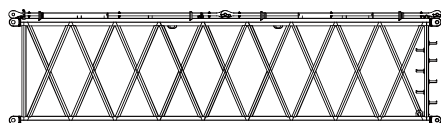

12m boominsert W5	× 1
L	12.23 m
W	4.43 m
H	3.25 m
W	11.77 t

Include pendant

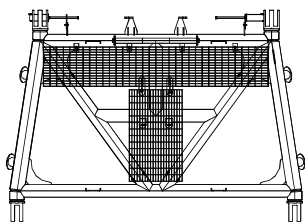

3m boominsert W6	× 1
L	3.23 m
W	4.43 m
H	3.25 m
W	6.79 t

Include pendant

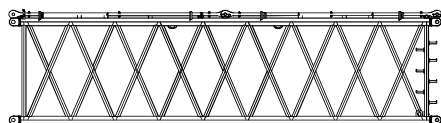

12m boominsert W7	× 2
L	12.23 m
W	4.43 m
H	3.25 m
W	13.9 t

Include pendant

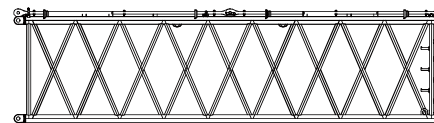

12m boominsert W8	× 1
L	12.23 m
W	4.43 m
H	3.25 m
W	13.9 t

Include pendant

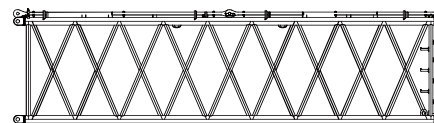

12m boominsert W9	× 1
L	12.23 m
W	4.43 m
H	3.25 m
W	13.32 t

Include pendant

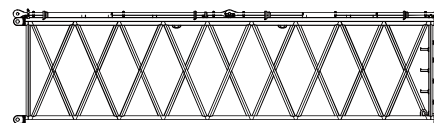

12m boominsert W10	× 1
L	12.23 m
W	4.43 m
H	3.25 m
W	10.16 t

Include pendant