

# Truck Crane



## XCT40U



40 US t



142 ft

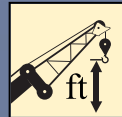

197 ft



# Content

<b>Content</b>	
Dimensions	3-4
Technical specifications	5
Boom lifting heights and weights	6-8
Jib lifting heights and capacities	9-10
Working area	11
Area of operation and Reeving diagram	12
Description of symbols	13
Notes	14

# Dimensions

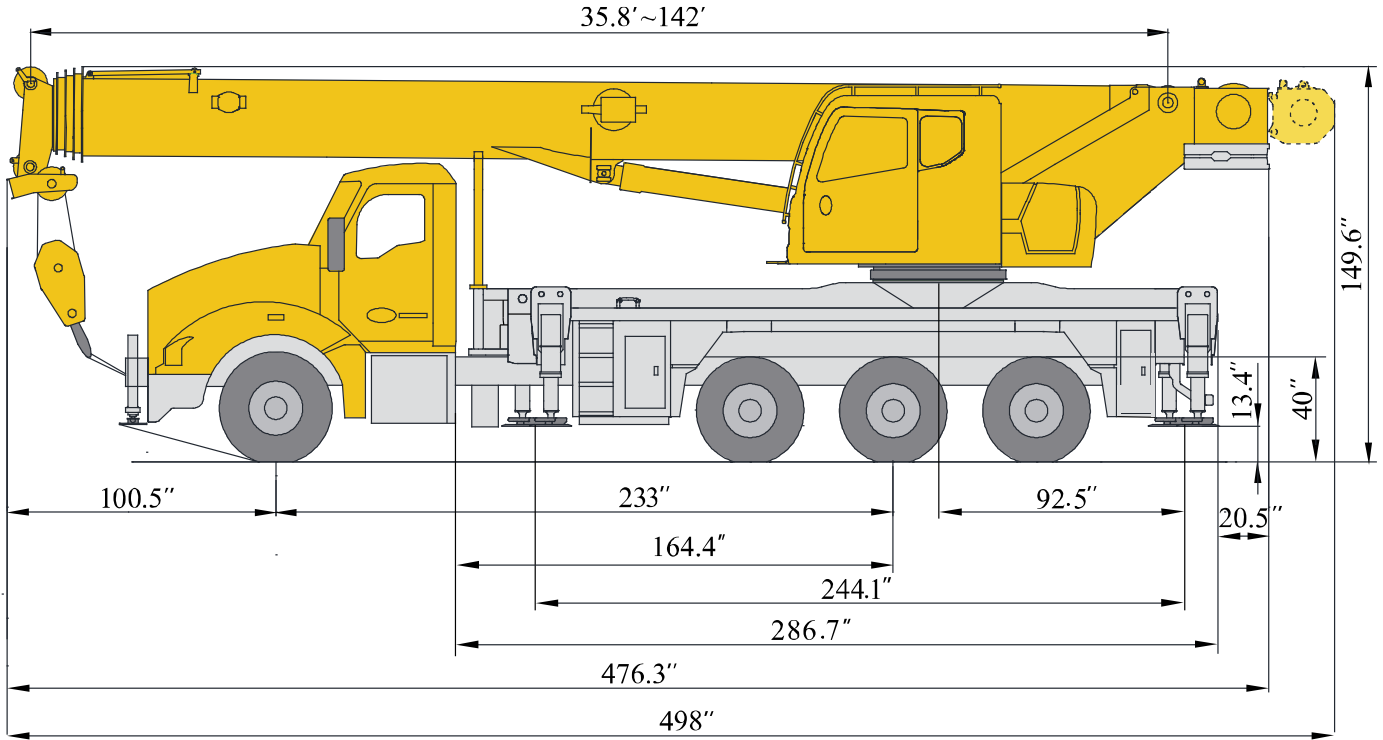

Front axle load/lb	Rear axle load/lb	Auxiliary axle load/lb	Min. front axle load/lb	Min. rear axle load/lb
20000	40000	13200	11596	8598



	Crane (standard)	Fix jib	Auxiliary winch (Include rope)	Fifth jack	Outrigger pad
Weight /lb	44775	1918	992	145	310



Hook	No. of sheaves	No. of lines	Weight/lb	Remarks
40 USt	4	8	794	Single hook
27.5 USt	3	6	440	Single hook
5.5 USt	—	1	220	Single hook

# Dimensions

**Full extended**

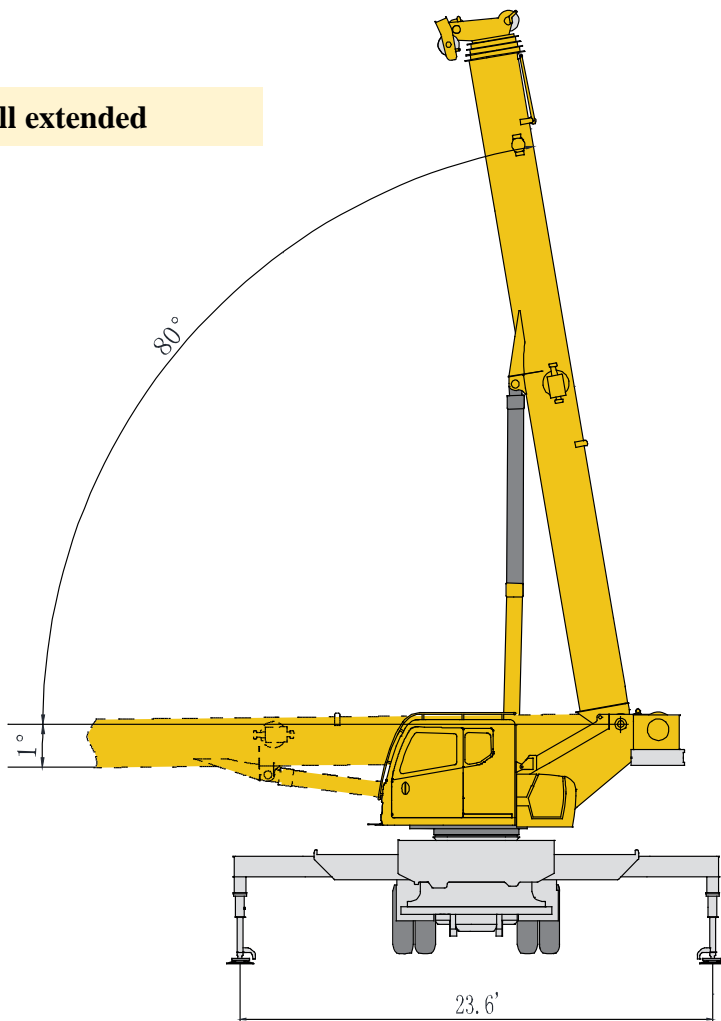

**Half extended**

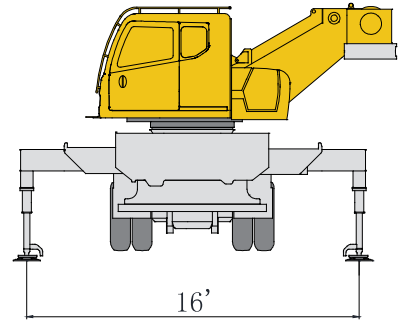

**Full retraction**

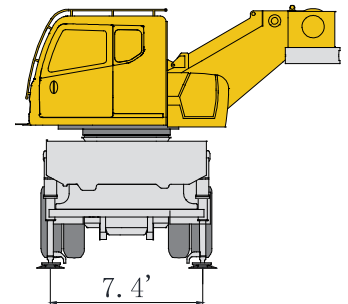

# Working speeds



Drive	Working speed	Max. single line pull	Rope diameter/ length
	0-443 fpm, single line, 4th layer	11023 lbs	5/8 in/410ft
	0-443 fpm, single line, 4th layer	6614 lbs	5/8 in/420ft
	0-2 r/min		
	Approx. 85s for boom elevation from -1° to 80°		
	Approx. 70s for boom extension from 35.8ft to 142ft		

# Technical specifications

## Intermediate frame

<b>Frame</b>	Designed and manufactured by XCMG, with all covered walking surface, made of high strength steel with inverted trapezoid cross section.
<b>Outrigger</b>	H-type outrigger beams with 4-point supported are wireless controlled. Wireless remote controller is standardly equipped. There is a mechanical control outrigger panel installed at rear side of chassis, with level gauge to level crane. The outrigger leg is stored under the outrigger jack with the ball hinge device. Fully-extended : 20.3ft×23.6ft half-extended : 20.3ft×16ft
<b>Hydraulic system</b>	The hydraulic system of outriggers is a constant displacement open-circuit system. The variable piston pump is connected to the transmission through PTO.

## Superstructure

<b>Frame</b>	Designed and manufactured by XCMG, made of high-strength steel.
<b>Hydraulic system</b>	Variable plunger pump is used for lifting, elevating, and telescoping; the gear plunger pump is used for slewing; load-sensing proportional multi-way directional control valve controlled by electric proportional pilot hydraulic oil is adopted; air-cooled hydraulic oil radiator is applied, which effectively reduces oil temperature of the system. Effective volume of oil tank: 149GAL
<b>Operating mode</b>	Pilot hydraulic proportional control is available. CAN bus power limit control system. In addition to the conventional control function, it also has the lifting planning, engine parameter virtual instrument display, fault diagnosis, etc.
<b>Main winch system</b>	Hydraulic control is used for speed regulation. The system is driven by a hydraulic motor through a planetary gear reducer, with a normally closed brake, a balanced valve and a grooved drum equipped.
<b>Operator's cab</b>	New fully-enclosed steel tiltable cab with a full-view front window. Safety glass and sun shield are used for windows. Wipers are fitted for the windshield and roof window. Standard controls and indicators are ergonomically arranged in the cab. The cab features a new ergonomic seat design with backrest adjustment and armrests with joysticks fitted. A sliding door and a pull-out step are available to make it easy and safe as access and egress the cab.

<b>Slewing system</b>	Hydraulic control is used for speed regulation. The system is driven by a hydraulic motor through a planetary gear reducer, with a normally closed brake, a balanced valve and a grooved drum equipped.
<b>Safety devices</b>	Hydraulic balance valve, Hydraulic relief valve, Double-way hydraulic valve, LMI. Lowering limiter for preventing wire rope from over-releasing. Anti-two block at boom head for preventing wire rope from over-winding.
<b>LMI</b>	The safety protection device is installed in operator's cab. When actual moment approaches overload value, it may send out visual alarm, and automatically stop dangerous movements before overloading. Overload memory function (black box) and fault self-diagnosis function are available.
<b>Counter-weight</b>	Total weight is 4409lbs, fixed counterweight.
<b>Hook block</b>	Hook block 5.5USt.

## Boom system

<b>Boom</b>	5-section, U-shape cross section welding structure. The double-cylinder plus ropes telescoping system. Two double-acting cylinders with safe valve assemblies used for control of the telescoping movement of all booms. Boom length:35.8ft ~ 142ft. Boom angle:-1°~80°
<b>Single top</b>	Fitted at boom head, used for 8 parts of line and single line operation . Its lifting performance is the same as that for boom, but the max. lifting load could not exceed 6614lbs.

## Optional equipment

<b>Auxiliary winch System</b>	Hydraulic control is used for speed regulation. The system is driven by a hydraulic motor through a planetary gear reducer, with a normally closed brake, a balanced valve and a grooved drum equipped.
<b>Operating mode</b>	Winch wireless remote controller
<b>Fix jib</b>	The jib consists of a connecting bracket, a rotating bracket and two lattice sections. Three offset angles of 0° , 15° and 30° are available. Jib length: 30.5ft, 53.5ft
<b>Hook block</b>	hook block 40USt , 27.5USt .
<b>Fifth jack</b>	Installed in front of the vehicle for ensuring the stability and safety during over front operation

**Product parts details** As mentioned above, please refer to the product quotation for specific parts.

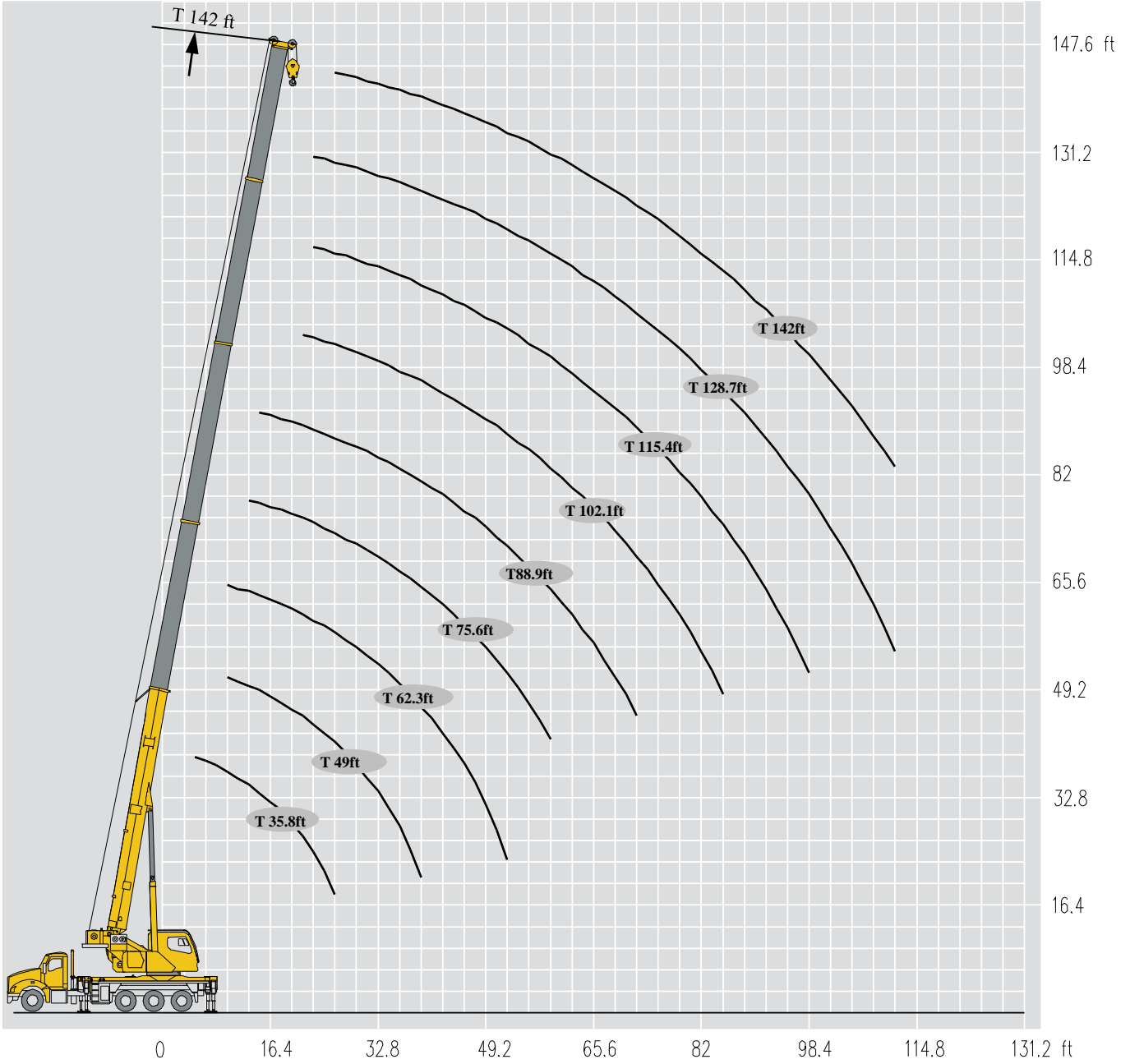

# Lifting capacities

T 35.8~142ft



ft	35.8 ft	49 ft	49 ft	62.3 ft	62.3 ft	62.3 ft	75.6 ft	75.6 ft	75.6 ft	88.9 ft	88.9 ft	ft
5	80020											5
7	70540											7
8	61720											8
10	55110	30860	44090	30860	28210	39680						10
11	55110	30860	44090	30860	28210	39680						11
13	49600	30860	43870	30860	28210	39680	28210	18950	30860			13
15	46290	30860	43650	30860	28210	39680	28210	18950	30860	18950	13880	15
16	43210	30860	41000	30860	28210	38580	28210	18950	30860	18950	13880	16
18	39020	30860	38130	30860	28210	35710	28210	18950	30860	18950	13880	18
20	34830	30860	35050	30860	28210	33500	28210	18950	30860	18950	13880	20
21	31740	29760	30860	30860	28210	30860	28210	18950	30420	18950	13880	21
23	29100	29100	28650	29760	28210	27330	28210	18950	28880	18950	13880	23
26	24250	26450	24250	25350	26450	23140	26010	18950	24690	18950	13880	26
30		22480	20500	22040	22700	19840	22040	18950	19840	18950	13880	30
33		19840	17410	18730	19840	16750	19620	18950	18070	18950	13880	33
36		16970	14550	15870	16970	13880	16530	18070	14990	17190	13880	36
39		14550	12340	13440	14550	11680	14320	15650	12780	14770	13880	39
43				11680	12560	9920	12340	13660	10800	12780	13880	43
46				10140	11020	8370	10800	12120	9250	11240	12340	46
49				8810	9700	7050	9470	10800	8150	9920	11020	49
52				7710	8590	5950	8370	9700	6830	8810	9920	52
59							6390	7710	5070	6830	7930	59
66										5510	6610	66
72										4400	5290	72

ft	88.9 ft	102.1 ft	102.1 ft	102.1 ft	115.4 ft	115.4 ft	115.4 ft	128.6 ft	128.7 ft	142 ft	ft
15	28210										15
16	27550										16
18	26890										18
20	25350										20
21	24250	13880	10360	18950							21
23	23360	13880	10360	18070	10360	8370	13880	8370	10360		23
26	21820	13880	10360	16750	10360	8370	13880	8370	10360	8370	26
30	20500	13880	10360	15650	10360	8370	13220	8370	10360	8370	30
33	18730	13880	10360	14770	10360	8370	13000	8370	10360	8370	33
36	15870	13880	10360	14100	10360	8370	12780	8370	10360	8370	36
39	13440	13880	10360	13440	10360	8370	12560	8370	10360	8370	39
43	11680	12780	10360	12120	10360	8370	12120	8370	10360	8370	43
46	10140	11680	10360	10580	10360	8370	11020	8370	10140	8150	46
49	8810	10360	10360	9250	10360	8370	9700	8370	9250	7930	49
52	7710	9030	9920	8150	9470	8370	8590	8370	8590	7490	52
59	5730	7270	8150	6390	7490	7710	6610	7490	7050	6390	59
66	4400	5730	6830	4850	6170	6830	5290	6390	5510	5730	66
72	3080	4620	5510	3740	4850	5730	3960	5070	4400	4620	72
79		3740	4620	2640	3960	4850	3080	4180	3300	3520	79
85		2860	3740	1980	3080	3960	2200	3300	2640	2860	85
92					2420	3300	1540	2640	1980	2200	92
98					1980	2640	1100	1980	1320	1540	98
105								1540	880	1100	105
112								1100		660	112

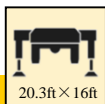
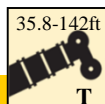

ft	35.8 ft	49 ft	49 ft	62.3 ft	62.3 ft	62.3 ft	75.6 ft	75.6 ft	75.6 ft	88.9 ft	88.9 ft	ft
5	80020											5
7	70540											7
8	61720											8
10	55110	30860	44090	30860	28210	39680						10
11	54010	30860	44090	30860	28210	39680						11
13	49600	30860	43870	30860	28210	39680	28210	18950	30860			13
15	46290	30860	43650	30860	28210	39680	28210	18950	30860	18950	13880	15
16	43210	30860	40560	30860	28210	38580	28210	18950	30860	18950	13880	16
18	37030	30860	35490	30860	28210	34610	28210	18950	30860	18950	13880	18
20	30860	30860	29540	30860	28210	28650	28210	18950	30200	18950	13880	20
21	26230	27990	24910	26670	28210	24030	27550	18950	25570	18950	13880	21
23	22700	24250	21380	22920	24470	20500	23800	18950	22040	18950	13880	23
26	17190	18950	16090	17630	18950	15430	18510	18950	16750	18950	13880	26
30		14990	12560	13880	15210	11900	14770	16310	13000	15430	13880	30
33		12340	9920	11240	12340	9250	11900	13440	10360	12560	13880	33
36		10140	7710	9030	10140	7050	9920	11240	8370	10360	11680	36
39		8370	6170	7490	8590	5510	8150	9700	6610	8810	9920	39
43				6170	7050	4180	6830	8150	5290	7270	8590	43
46				5070	5950	3080	5730	7050	4180	6170	7270	46
49				3960	5070	2200	4850	6170	3300	5290	6390	49
52				3300	4180	1540	3960	5290	2420	4400	5510	52
59							2640	3960	1320	3080	4180	59
66										2200	3080	66
72										1320	2420	72

ft	88.9 ft	102.1 ft	102.1 ft	102.1 ft	115.4 ft	115.4 ft	115.4 ft	128.6 ft	128.7 ft	142 ft	ft
15	28210										15
16	27550										16
18	26890										18
20	25350										20
21	24250	13880	10360	18950							21
23	22920	13880	10360	18070	10360	8370	13880	8370	10360		23
26	17630	13880	10360	16750	10360	8370	13880	8370	10360	8370	26
30	13880	13880	10360	14550	10360	8370	13220	8370	10360	8370	30
33	11240	13000	10360	11680	10360	8370	12340	8370	10360	8370	33
36	9030	10800	10360	9700	10360	8370	10140	8370	10360	8370	36
39	7490	9030	10140	7930	9470	8370	8370	8370	8810	8370	39
43	6170	7710	8810	6610	7930	8370	7050	8150	7270	7710	43
46	5070	6610	7490	5510	6830	7710	5950	7050	6170	6390	46
49	3960	5510	6610	4620	5950	6830	5070	6170	5290	5510	49
52	3300	4850	5730	3740	5070	5950	4180	5290	4400	4620	52
59	1980	3520	4400	2420	3740	4620	2860	3960	3080	3300	59
66	880	2420	3300	1540	2640	3520	1760	2860	2200	2420	66
72		1540	2640		1980	2640	1100	2200	1320	1540	72
79		880	1760		1320	1980		1320		880	79
85			1320			1540		880			85
92						880					92

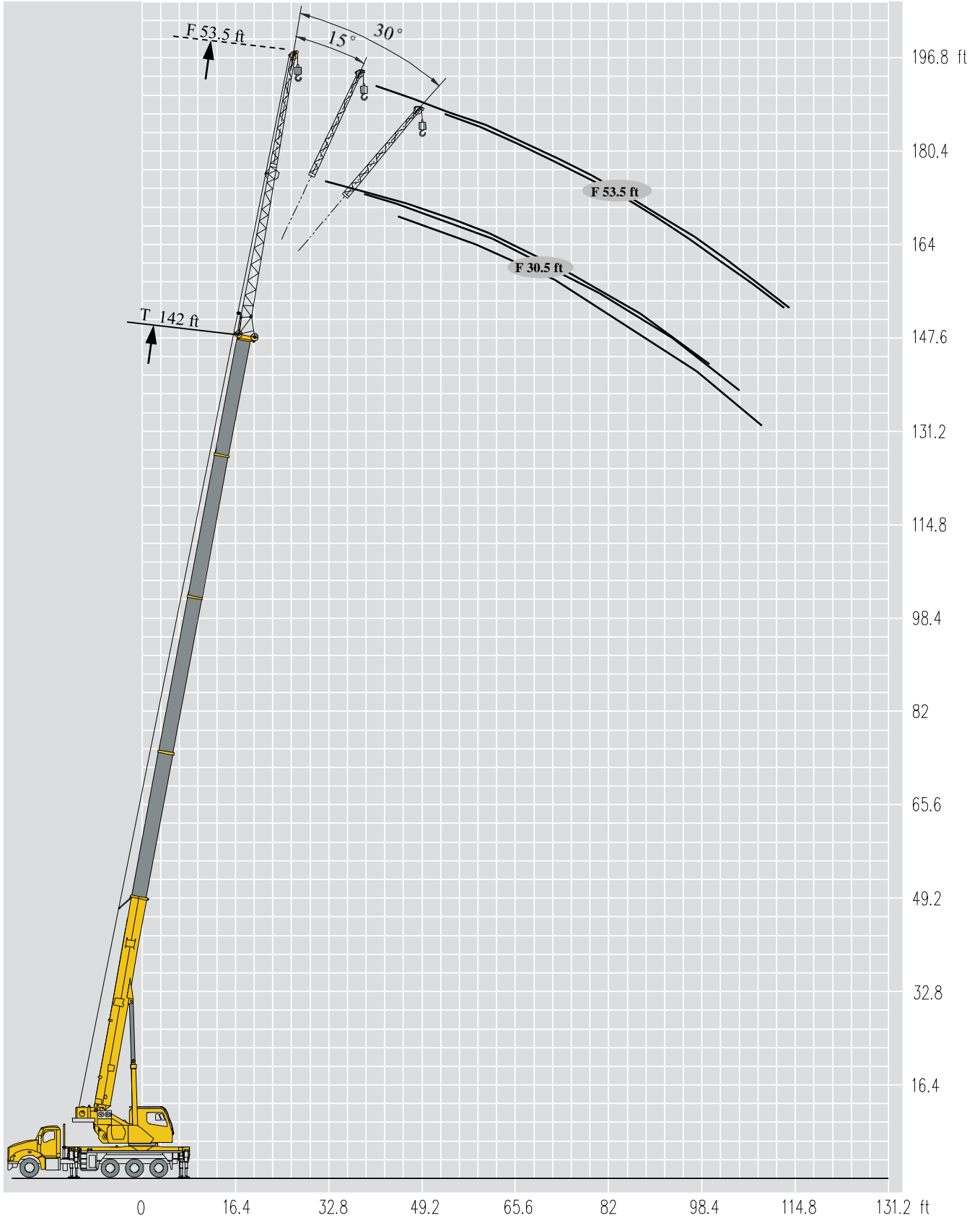

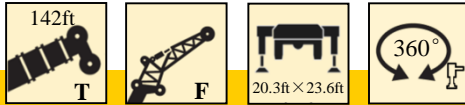

	142 ft			142 ft		
	30.5 ft			53.5 ft		
	0°	15°	30°	0°	15°	
	79	3740	3300	2640	2200	
78	3520	3260	2640	1980	1050	78
75	3190	3190	2640	1870	990	75
72	3080	3080	2420	1650	880	72
70	2860	2860	2420	1540	880	70
65	2750	2640	2420	1320	770	65
60	2640	2420	2200	1100	660	60
55	1760	1540	1540	770		55
50	880					50

# Working area

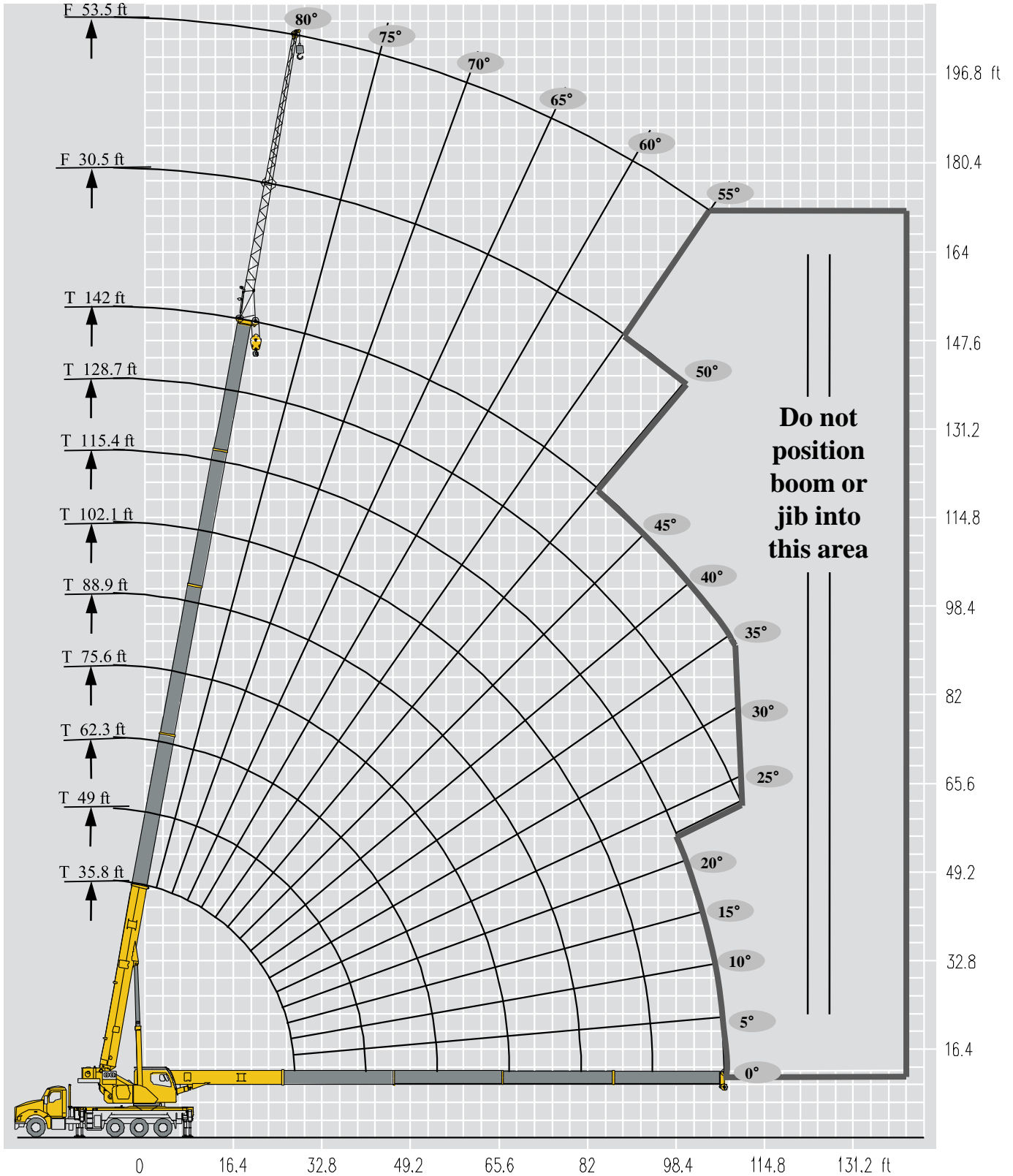

# Area of operation

In order to take advantage of full 360° rotation, the fifth jack must be set in accordance to the manual before working in this area and machine must be level.

If the fifth jack was lowered down, the crane only can be operated with the boom over side or over rear of the crane.

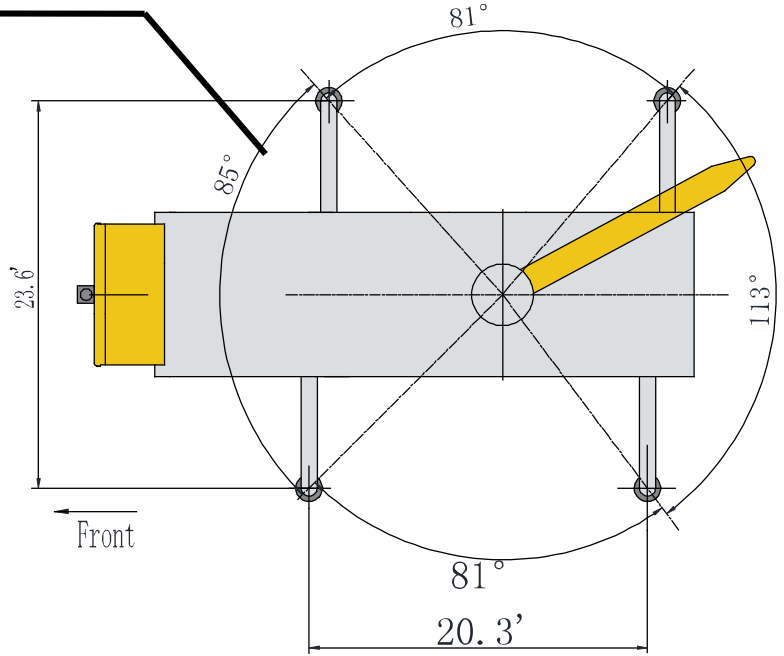









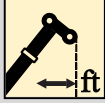

# Reeving diagram

Allowable line pull								Warning
8 part line	7 part line	6 part line	5 part line	4 part line	3 part line	2 part line	1 part line	Refer to the owners manual  Incorrect reeving or incorrect input of parts of line may result in serious accidents.  Keep at least three turns of rope left on the drum at all times
82252 lbs	72683 lbs	62913 lbs	52954 lbs	42787 lbs	32412 lbs	21826 lbs	11023 lbs	
								Min. breaking strength --56217lbs

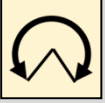
# Description of symbols

## General symbols

	Outriggers		Axle load
	Chassis		Radius
	Boom position		Boom length
	Hook block		Over side or over rear of the crane
	360° rotation with 5 <sup>th</sup> jack		Superstructure
	Main winch		Auxiliary winch

## Crane specific symbols

	Boom		Fix jib
--	------	---	---------

1. Total rated load shown in the tables is the maximum lifting capacity when the crane is set up on firm and level ground.
2. Total rated load shown in the tables includes the weight of hook block, slings and wire rope between boom head and hook block.
3. The working radius shown in the tables are the radius when the loads are lifted off ground, they are the actual values including loaded boom deflection, therefore boom deflection should be taken into consideration before lifting.
4. A lifting operation is permissible only when the wind force is below grade 5 (instantaneous wind speed is 46ft/s, wind pressure is 125 N/m<sup>2</sup>).
5. Boom angle and lifting height in the tables are reference values, take working radius as standard.
6. The operator must select proper working condition after understanding load weight and working range before lifting, it is forbidden to exceed the values in the table. When the radius and boom length are between two adjacent values, the smaller value should be selected to confirm lifting operation.
7. Data listed in the tables are rated lifting capacity without jib attached, when jib is installed on boom head, the rated lifting capacity of boom should minus 2646lb.
8. The max. outrigger counter-force is 62986 lbs.
9. The operation should be in accordance with boom angle range, it cannot be exceeded ever if no load so as to avoid whole crane tipping.
10. The total rated load for single top is the same as that for the boom, and the max. lifting load should not exceed 6613lb.



Add : No.165 Tongshan Road Xuzhou Jiangsu China

Tel : 0516-83462242/83462350

Quality Inquiry Tel : 0516-87888268

Spare Parts Tel : 0516-83461542

Post Code : 221004

Web : [www.xcmg.com/qizhongji](http://www.xcmg.com/qizhongji)

**Service Tel**

**400-110-9999**

**400-001-5678**



This print does not belong to the contract. We reserve the right to modify the design (such as product model, parameters and configuration) without notice for improvement. The pictures are just for reference. The product in the picture may not be standard configuration. Some parts need to be purchased separately. Conform to the local laws for license application and road traveling.